

1. AIR CONDENSER CLEANING:

1. Disconnect the unit from the electricity.
2. Clean condenser using a vacuum cleaner, soft brush or low pressure air. Clean from top to bottom, not side to side. Be careful not to bend the condenser fins.
3. Connect the unit to the electricity.

2. WATER CONDENSER CLEANING:

1. Disconnect the unit from the electricity.
2. Close the inlet water faucet.
3. Disconnect the condenser water inlet and outlet.
4. Prepare a solution with 50% phosphoric acid and distilled water. **Do not use hydrochloric acid**. We recommend using the cleaning product Calklin. The mixture is more effective if the water is between 35°C and 40°C. Flow the solution through the condenser for about 10 minutes using a recirculating pump.
5. Empty the product from the condenser and connect the condenser water inlet and outlet.
6. Open the water faucet.
7. Connect the unit to the electricity

3. WATER FILTER REPLACE

1. Disconnect the unit from the electricity.
2. Close the inlet water faucet.
3. Close the faucets before and after the filter.
4. Remove the old cartridge and replace it with a new one.
5. Open all the closed faucets.
6. Connect the unit to the electricity.

4. WATER CIRCUIT CLEANING:

1. Set the switch to the OFF position
2. Set the switch to the OFF position after ice falls from the evaporator at the end of a harvest cycle, or set the switch to the OFF position and allow the ice to melt off the evaporator.

CAUTION: Never use anything to force ice from the evaporator.

3. Remove the back metal lid and the top panel (if it needs to be made easier for the cleaning operations).

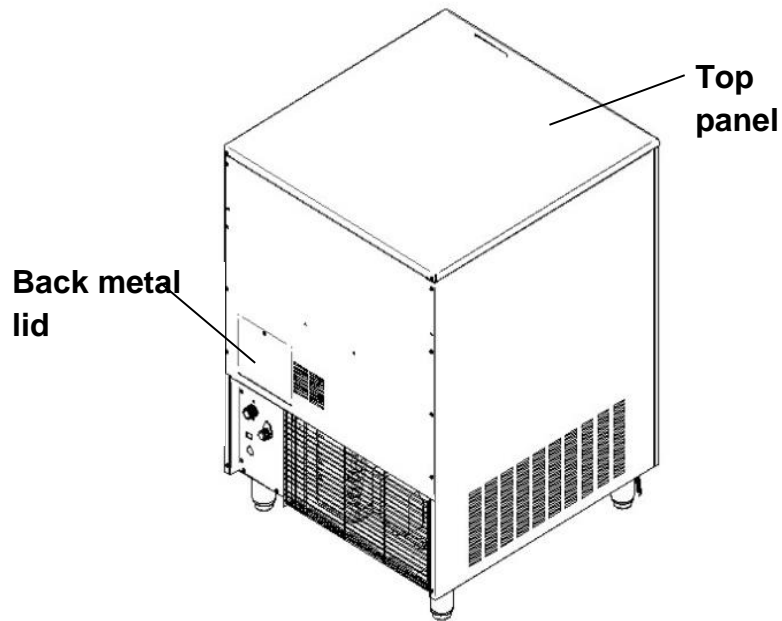

4. Remove all ice from the bin.
5. Remove the auxiliary pipe for drain operations near the pump and empty the water tray. Return it to their original position to avoid water spill.

Pump drain

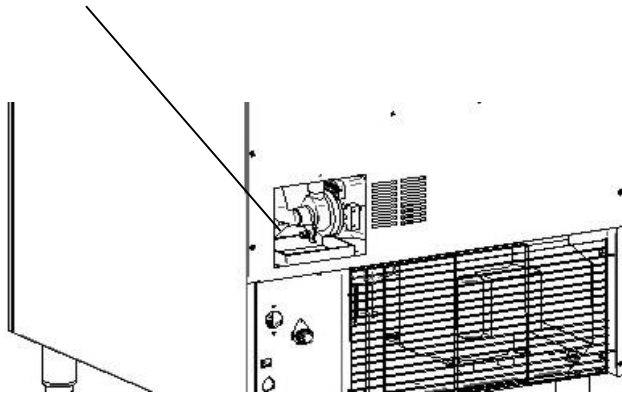

6. Prepare a solution of an appropriate product for the cleaning of ice machines (lime). Do not use hydrochloric acid. We recommend the use of any NSF approved scale removal product prepared according to the manufacturer's instructions.
7. Fill water tray with the solution.

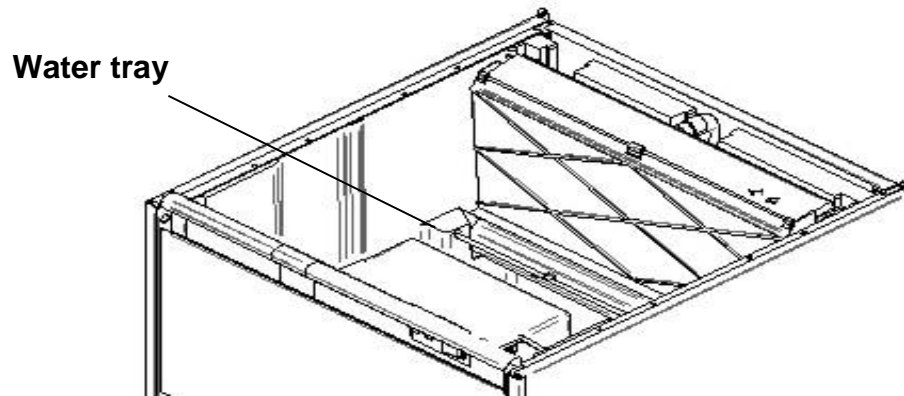

8. Compressor switch (see figure below) to position 0, and switch on machine in order to run water pump. Let solution stand for 30-40 minutes and then switch off the machine.

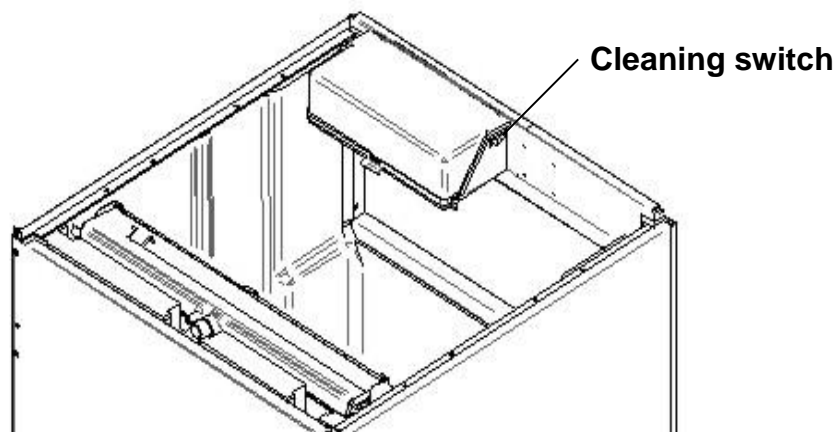

9. Disconnect power.
10. Remove the auxiliary pipe to drain and purge out the ice machine scale remover and residue. Replace it.
11. Mix enough cleaning solution (as in point 5) to clean parts and interior food zone surfaces.
12. Remove the curtain.

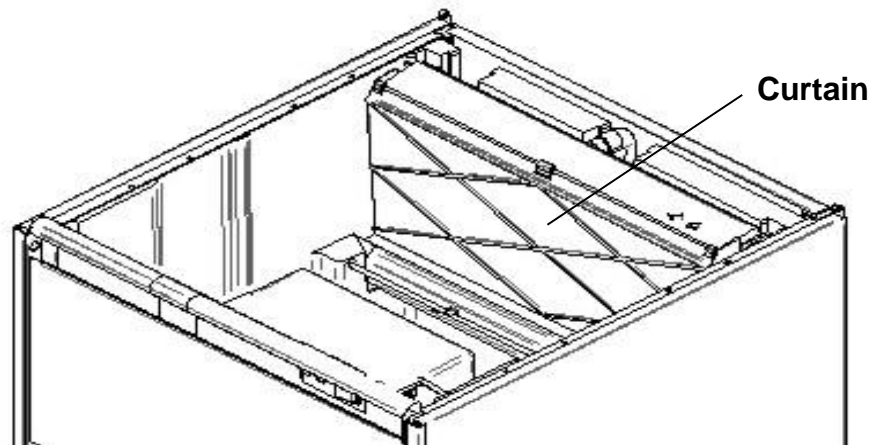

13. Clean all surfaces of the shield with the cleaner solution using a brush (not a wire brush) or cloth. Rinse all areas with water.
14. Clean all the interior surfaces of the freezing compartment (including storage bin) with the cleaner solution using a brush or cloth. Rinse all areas with water.
15. Mix a solution of sanitizer using sodium hypochlorite food equipment sanitizer to form a solution with 100 - 200 ppm free chlorine yield.
16. Sanitize all surfaces of the shield applying liberally the sanitizer solution using a cloth or sponge.
17. Sanitize all the interior surfaces of the freezing compartment (including the storage bin) applying liberally sanitizer solution, using a cloth or sponge.
18. Return the curtain to its position.
19. Connect power and water supplies.
20. Fill water reservoir with the sanitizer solution.
21. Switch on machine in order to run water pump. Let solution stand for 20 minutes and switch off.
22. Remove the auxiliary pipe to drain and purge out the sanitizer solution and residue. Replace it. Fill the water reservoir with water and switch on the machine to allow water to circulate for 5 minutes and then stop the machine. Repeat this operation two more times to rinse thoroughly.
23. Remove the auxiliary hose to drain the water. Replace it and fill the tray with water to ensure the pump works properly.
24. Switch on compressor switch (I position).
25. Return the back metal lid and the top panel to their position.
26. Switch on machine and discard the first two harvests.

Stock bin cleaning.

1. Disconnect the machine, close water faucet and empty storage bin of ice
2. Use the cleaner/water solution to clean all surfaces of the bin. Use a nylon brush or cloth. Then rinse all areas thoroughly with clean water.
3. Use the sanitizer/water solution to sanitize all surfaces of the bin. Use a nylon brush or cloth.

Exterior cleaning

Clean the area around the ice machine as often as necessary to maintain cleanliness. Sponge any dust and dirt off the outside of the ice machine with mild soap and water. Wipe dry with a clean soft cloth. A commercial grade stainless steel cleaner/polish can be used as necessary

5. MAINTENANCE TABLE:

MAINTENANCE	Dusty ambient	Normal ambient
Air condenser cleaning	6 months	12 months
Water condenser cleaning	6 months	12 months
MAINTENANCE	Hard water (over 400ppm)	Soft water (less than 400 ppm)
Water filter changing	6 months	12 months
Hydraulic circuit cleaning	6 months	12 months
Injectors cleaning	6 months	12 months
Sanitation cleaning	6 months	6 months
Exterior cleaning	To do by user	To do by user
Stock bin cleaning	To do by user	To do by user

During the maintenance visit, check the connections on the electric board.