

1. AIR CONDENSER CLEANING:

1. Disconnect the unit from the electricity.
2. Clean condenser using a vacuum cleaner, soft brush or low pressure air. Clean from top to bottom, not side to side. Be careful not to bend the condenser fins.
3. Connect the unit to the electricity.

2. WATER CIRCUIT CLEANING:

1. Disconnect the unit from the electricity.
2. Closet the inlet water faucet.
3. Disconnect the condenser water inlet and outlet .
4. Prepare a solution with 50% phosphoric acid and distilled water. **Do not use hydrochloric acid.** We recommend using the cleaning product Calklin. The mixture is more effective if the water is between 35°C and 40°C. Flow the solution through the condenser for about 10 minutes using a recirculating pump.
5. Empty the product from the condenser and connect the condenser water inlet and outlet.
6. Open the water faucet.
Connect the unit to the electricity.

3. WATER FILTER REPLACE

1. Disconnect the unit from the electricity.
2. Closet the inlet water faucet.
3. Close de faucets before and after the filter.
4. Remove the old cartridge and replace it with a new one.
5. Open all the closed faucets.
6. Connect the unit to the electricity.

4. WATER CIRCUIT CLEANING:

1. Remove the top cover screws to remove the cover.

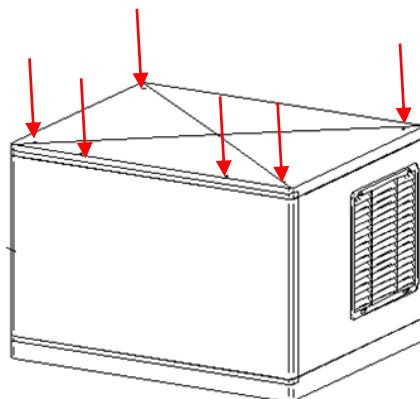

2. Remove the front door.

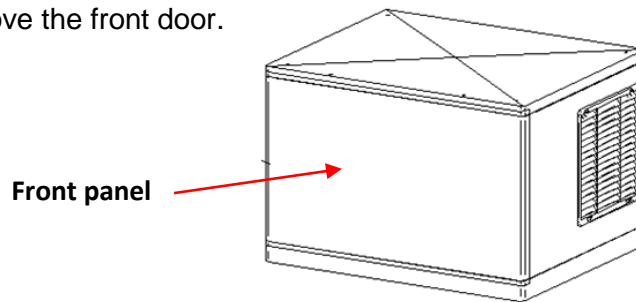

3. Set Ice-wash switch to the OFF position (position 0) after ice falls from the evaporator at the end of a harvest cycle, or set the ice-wash switch to the OFF position and allow the ice to melt off the evaporator.

CAUTION: Never use anything to force ice from the evaporator. Damage may result

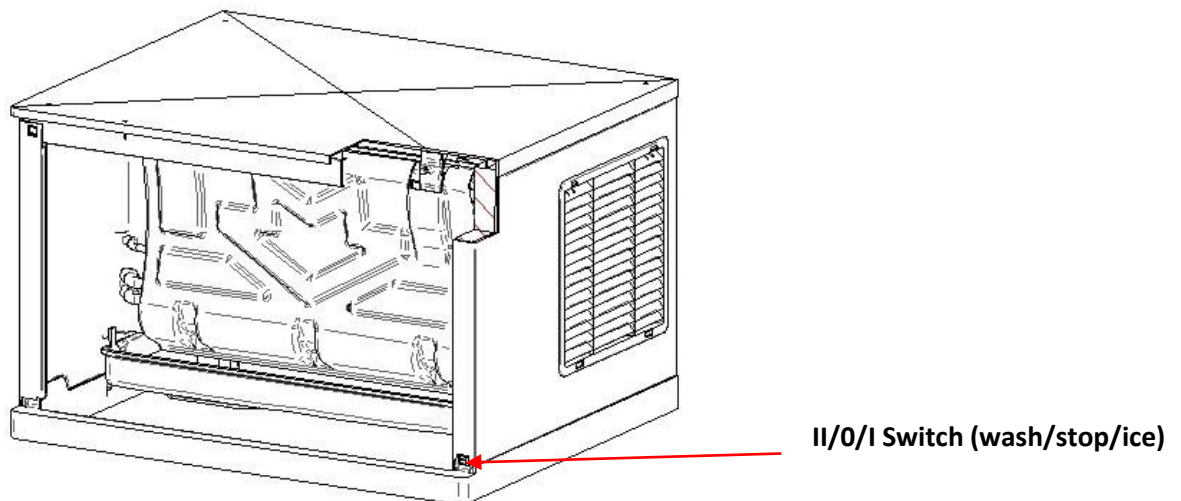

4. Prepare a solution of an appropriate product for the cleaning of ice machines (lime). Do not use hydrochloric acid. We recommend the use of any NSF approved scale removal product. In modular machines the water bucket is filled automatically so we recommend to prepare a previous solution (for example 1,89 liters(0,15 Gal)) according to the manufacturer's instructions with the total quantity of product needed for the water tray (3 liters (0,8 gal) for MS 220/440 and 6 liters (1,6 gal) for MS 410/880).
5. To start a cleaning cycle, move the ice-wash switch to the WASH position (position II). The machine will drain the reservoir and refill it. Pour the scale remover solution into the reserve.

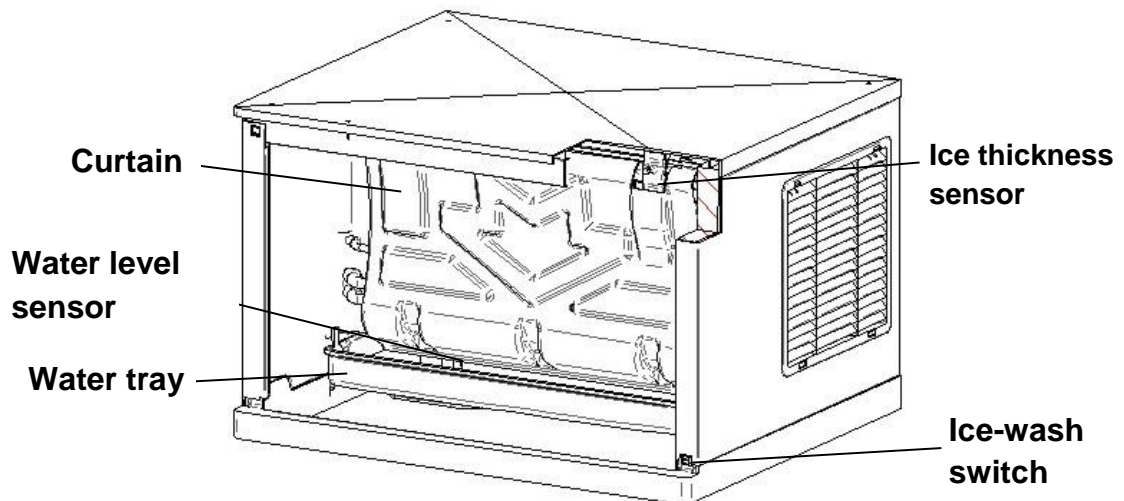

6. Allow the solution to circulate in the water system for 30-40 minutes and then set the ice-wash switch to the OFF position (0).
7. To purge out the ice machine scale remover and residue move the ice-wash switch to the WASH (the machine will drain the reservoir and refill it) and then set the ice-wash switch to the OFF position (0).
8. Disconnect power and close water supply.
9. Mix a cleaning solution.
10. Remove shield and water tray.
11. Clean the metal surfaces of the thickness sensor, water level sensor, the adjustment screw, the shield and the water tray with the cleaner solution using a brush (not a wire brush) or cloth.

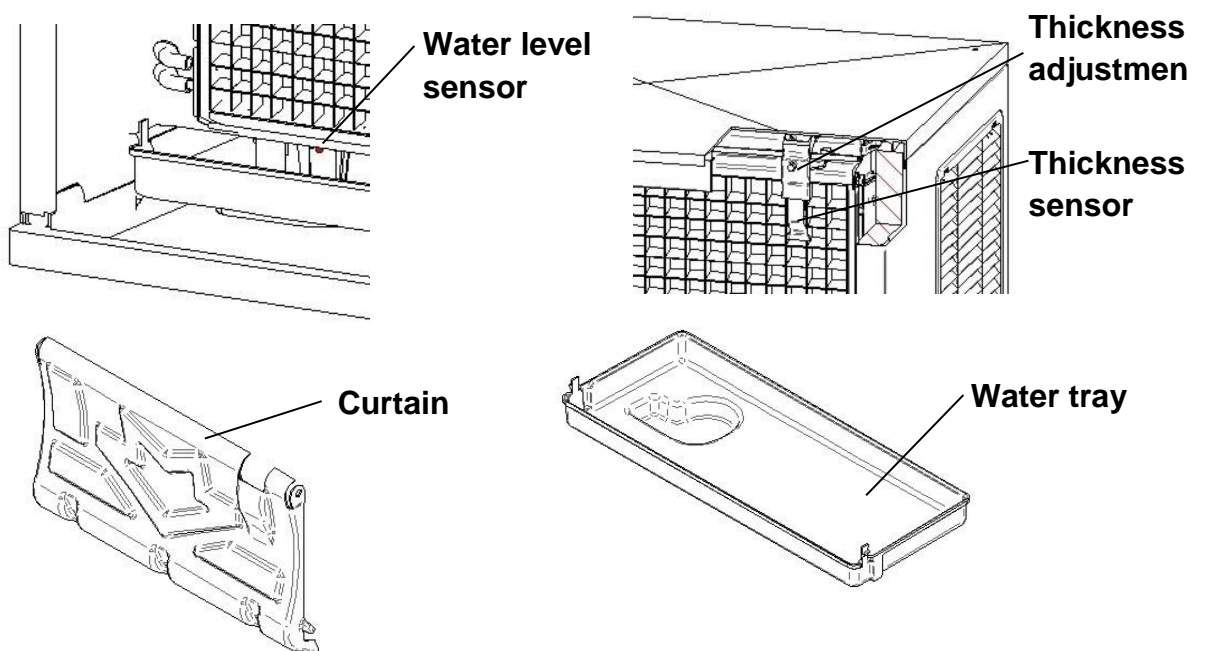

12. Clean the interior surfaces of the freezing compartment (including walls, plastic parts of the evaporator, distributor...) and the front panel with the cleaner solution using a brush or cloth.
13. Mix a solution of sanitizer using approved sodium hypochlorite food equipment sanitizer to form a solution with 100 t 200 ppm free chlorine yield.
14. Sanitize all surfaces of the ice thickness sensor, water level sensor, shield and water tray applying liberally the sanitizer solution using a cloth or sponge.
15. Sanitize the interior surfaces of the freezing compartment (including walls, plastic parts of the evaporator, distributor...) and the front panel applying liberally the sanitizer solution using a cloth or sponge.
16. Return the water tray and shield to their normal positions.
17. Connect power and water supplies.
18. To start a sanitation cleaning cycle, move the ice-wash switch to the WASH position. The machine will drain the reservoir and refill it. Pour the sanitizer into the water reservoir to get a solution as in the point 12 (the volume in the water tray is approximately 3 liters(0.8 gal) for MS 220/440) and 6 liters (1.6 gal) for MS 410/880).
19. Allow the solution to circulate in the water system for 20 minutes and then set the ice-wash switch to the OFF position (0).
20. To purge out the sanitizer solution and residue move the ice-wash switch to the WASH position (drain and refill) and allow the water to circulate for 5 minutes and then move the switch to the OFF position (drain). Repeat this operation two more times to rinse thoroughly.
21. Return the panel to their position.
22. Set the ice-wash switch to the ON position (position I) and discard the first two harvests.

5. MAINTENANCE TABLE:

MAINTENANCE	Dusty ambient	Normal ambient
Air condenser cleaning	6 months	12 months
MAINTENANCE	Hard water (over 400ppm)	Soft water (less than 400 ppm)
Water filter changing	6 months	12 months
Hydraulic circuit cleaning	6 months	12 months
Sanitation cleaning	6 months	6 months