

M SPIKA 200-400  
 R404A  
 CIRCUITO HIDRAULICO

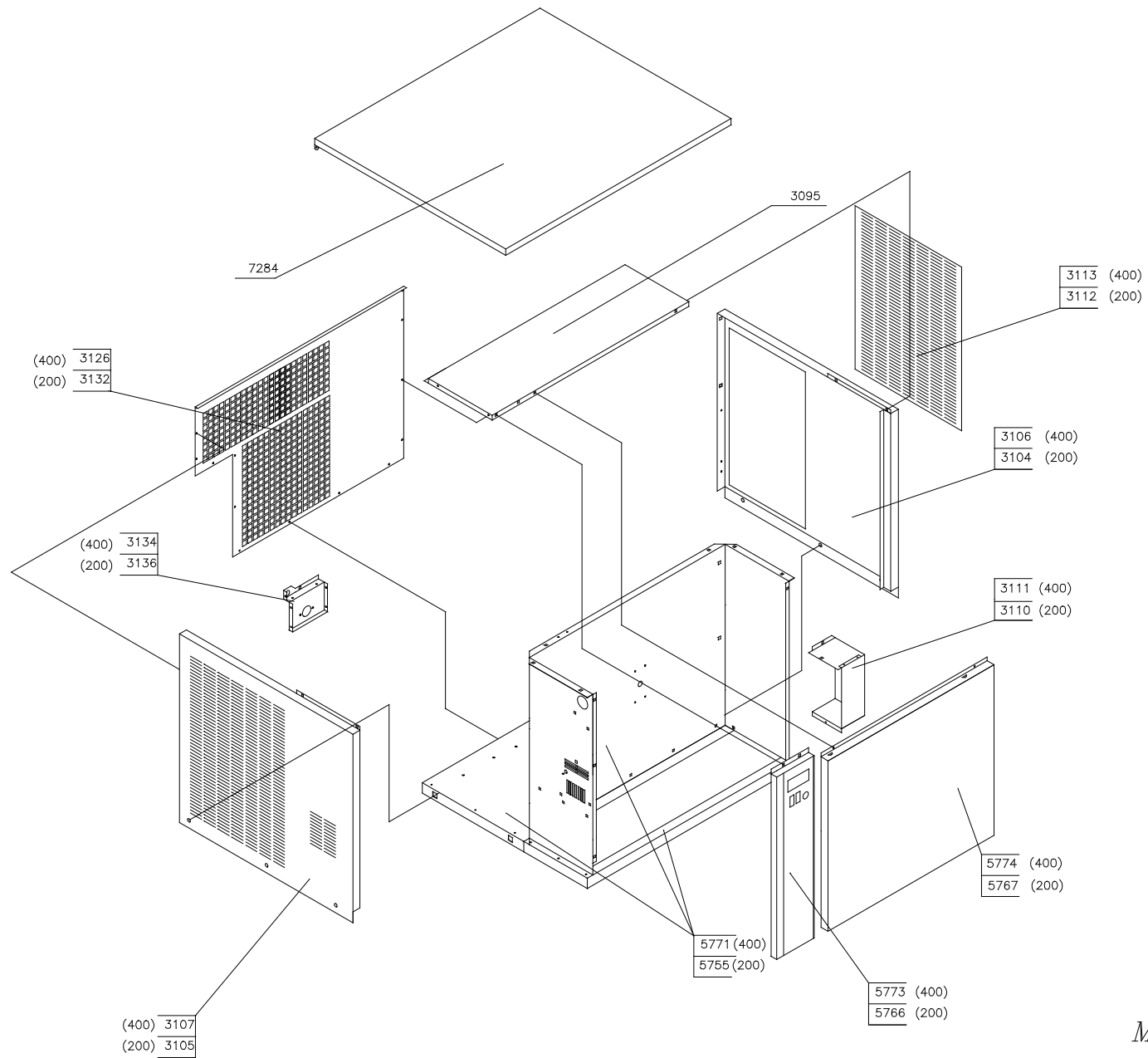

M SPIKA 200-400  
CARROCERIA

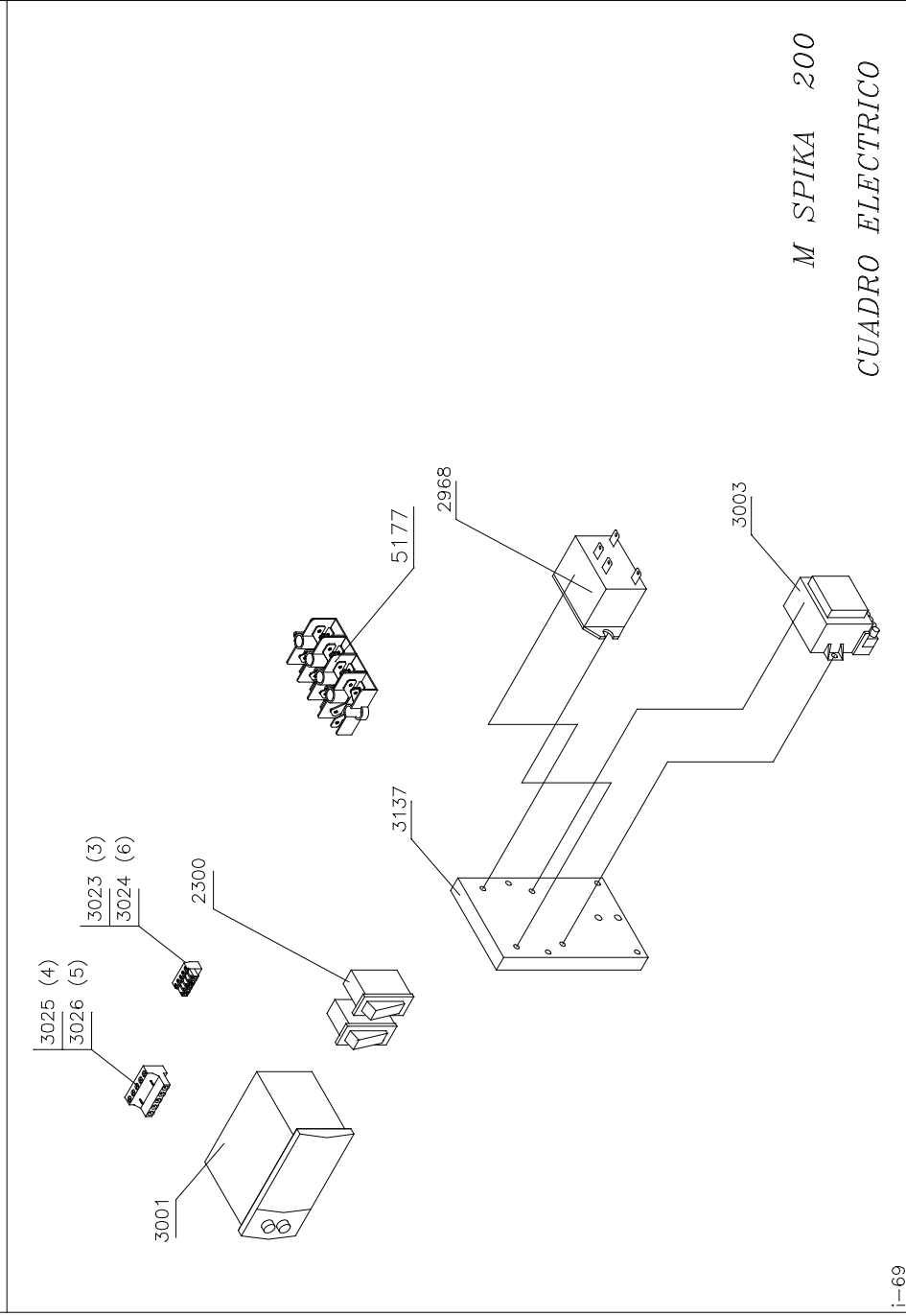

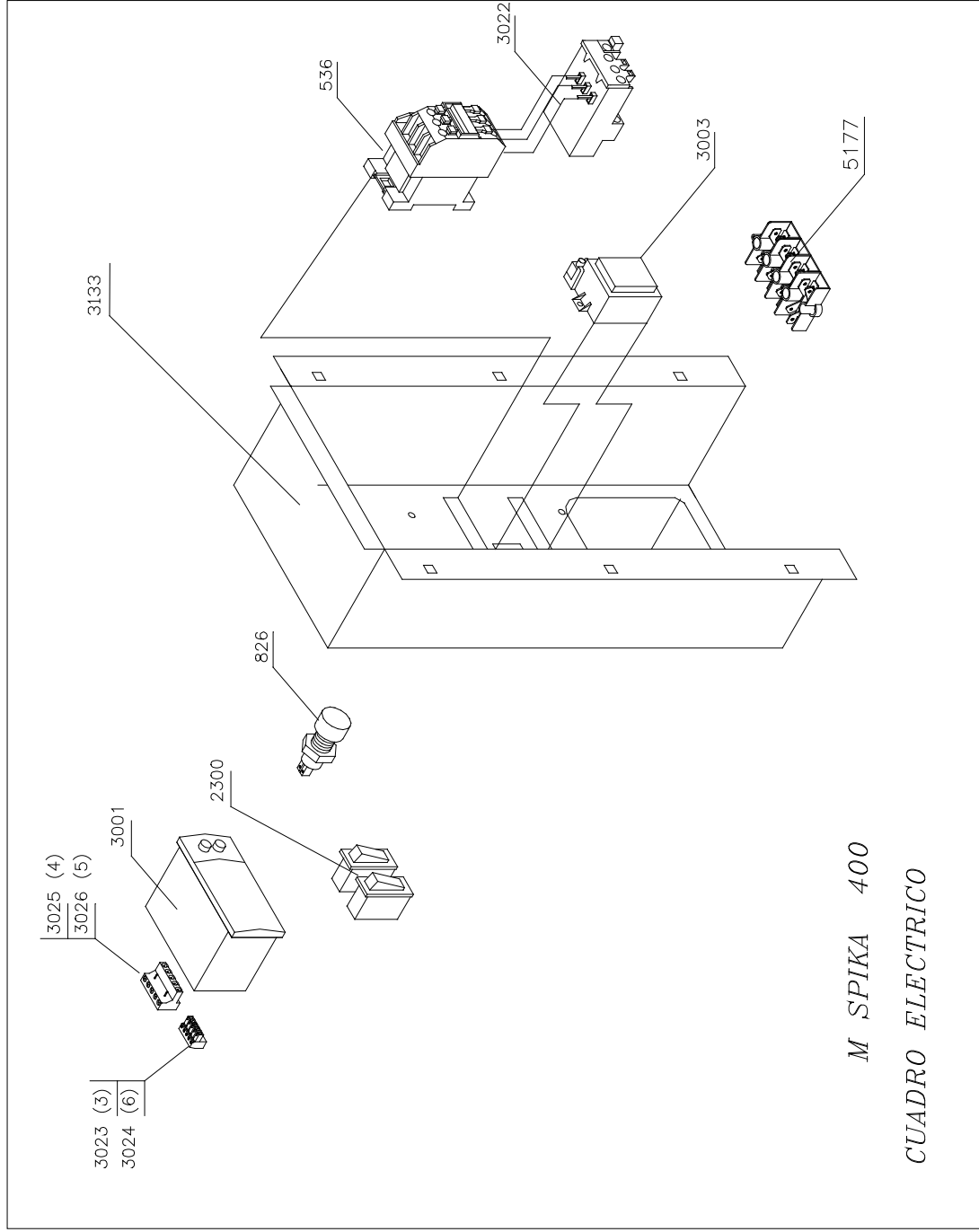
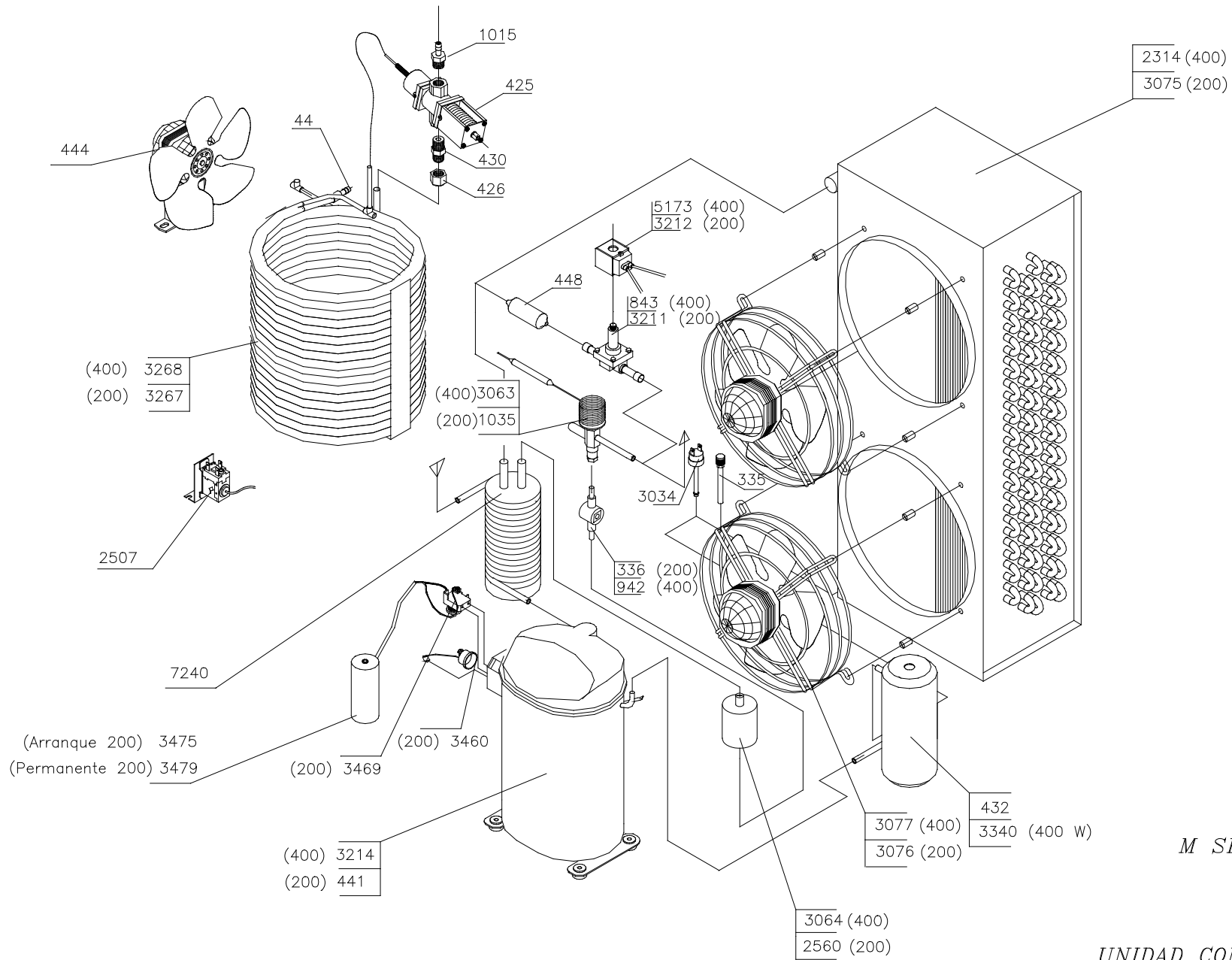

M SPIKA 200-400

R404A

UNIDAD CONDENSADORA