

1. INTRODUCTION

Thank you for buying an ice cube machine from the 'NIQ' range. You have purchased one of the most reliable ice machines on the market today.

Carefully read the instructions contained in this manual for important information on safety during installation, use and maintenance.

1.1 WARNING

- This appliance is intended to be used in household and similar applications such as: staff kitchen areas in shops, offices and other working environments; farm houses and by clients in hotels, motels and other residential type environments; bed and breakfast type environment; catering and similar non-retail applications.
- The installation of this equipment should be done by the Technical Assistance Service department.
- The socket should always be placed on an accessible location.
- When positioning the appliance, ensure that the power cable is not trapped or damaged.
- Do not place multiple portable socket outlets or portable power sources in the rear of the appliance
- ALWAYS disconnect the power supply from the machine BEFORE any cleaning or maintenance service.
- Any change needed on the electrical installation for the appropriate connection of the machine, should be exclusively performed by qualified and certified professional personnel only.
- Any use by the ice maker not intended to produce ice, using drinking water, is considered inappropriate.
- It is extremely dangerous to modify or intend to modify this machine and shall make any type warranty void.
- This device is not intended for use by persons (including children) whose physical, sensory or mental capacities are limited, or who lack sufficient experience or knowledge, unless they are acting under the supervision of or have received instruction regarding proper use of the device from a person responsible for their safety. Children should be supervised to ensure they do not play with the device.
- Children should be monitored to assure that they should not play near the equipment.
- This machine is not intended to be used outdoors nor exposed to the rain.

- Connect to potable water supply only. See section 3 of this manual.
- This machine must be grounded to prevent possible discharges on persons or damage to the equipment. The machine must be grounded according to local and/or national regulations and regulations in each case. The manufacturer will not be responsible for the damage caused by the lack of grounding of the installation.
- To guarantee the efficiency of this machine and its correct operation, it is essential to adhere to the manufacturer's instructions, especially as regards maintenance and cleaning operations, which must only be carried out by qualified personnel.
- This equipment must be installed with adequate return flow protection to comply with federal, state and local codes that are applicable.

ATTENTION: *The intervention of unskilled people, besides being dangerous, can cause serious damage. In case of a breakdown, contact your distributor. We recommend always using original spare parts.*

The company reserves the right to make changes in specifications and design without prior notice.

REMEMBER THAT MAINTENANCE AND CLEANING OPERATIONS ARE NOT INCLUDED IN THE WARRANTY AND THEREFORE, WILL BE INVOICED BY THE INSTALLER.



This signal indicates “Risk of fire / Flammable materials” because of the use of flammable refrigerant.

For compression-type **appliances that use flammable refrigerants** should additionally consider the substance of the warnings listed below:

- Keep ventilation openings, in the appliance enclosure or in the built-in structure, clear of obstruction.
- Do not use mechanical devices or other means to accelerate the defrosting process, other than those recommended by the manufacturer.
- Do not damage the refrigerant circuit.
- Do not use electrical appliances inside the food storage compartments of the appliance, unless they are of the type recommended by the manufacturer.

- Do not store explosive substances such as aerosol cans with a flammable propellant in this appliance.

In case of refrigerant leakage:

- Do not generate flames close to the appliance.
- Do not switch on/off or plug in/off the appliance.
- To ventilate immediately the area where appliance is located by opening doors and/or windows.
- To call to an authorized technical service.

2. RECEPTION OF THE MACHINE

Inspect the outside packing. In case of damages, MAKE THE CORRESPONDING CLAIM TO THE CARRIER.

To confirm the existence of damages, UNPACK THE MACHINE IN THE PRESENCE OF THE CARRIER and state any damage on the equipment on the reception document, or on a separate instrument. As from May 1, 1998 complies with the European regulations on management of packing and packing waste, inserting the "Green Dot Label" on all their packages.

Always state the machine number and model. This number is printed on three locations:



Figure I

Packing

On the outside, it contains a label with the manufacturing number.

Exterior of the equipment

On the back of the equipment, there appears a label with the same characteristics as the previous one.

Nameplate

On the back of the machine.

Check that in interior of the machine the installation kit is complete and comprises:

- Water connection $\frac{3}{4}$ gas with a filter gasket
- Drainage hose (22 mm).
- Manual.
- Warranty card.

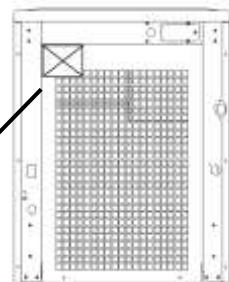
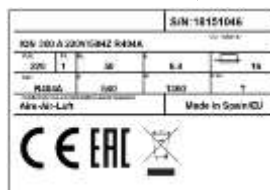

Figure II



CAUTION: ALL PACKING ELEMENTS (plastic bags, carton boxes and wood pallets) SHOULD BE KEPT OUTSIDE THE REACH OF CHILDREN, AS THEY ARE A SOURCE OF POTENTIAL HAZARD

3. INSTALLATION

THIS ICE MAKER IS NOT DESIGNED FOR OUTDOOR OPERATION.

An incorrect installation of the equipment may cause damages to individuals, animals or other materials, being the manufacturer not responsible for such damages.

CAUTION:

The NG DP machines are designed to operate at room temperature between 10°C (50°F) and 43°C (109.40°F).

Below the minimum temperatures, the gear motor is forced excessively. Above the maximum, compressor life is shortened and production decreases considerably.

Do not place anything on the fabricator or against the front grille.

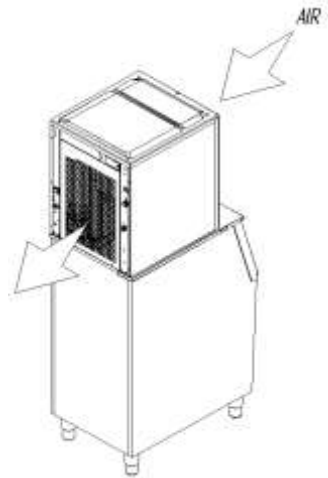

Figure III

For condensed air machines (Figure III), if the front air intake is insufficient, the exit is totally or partially obstructed, or if by its placement it is going to receive hot air from another device, we strongly advise, in case of not being able to change the site of the machine, INSTALL A WATER CONDENSER.

3.1 CONNECTIONS TO THE WATER NETWORK

Use a flexible pipe (1.3 m – 4.27 feet length) with the two filter joints supplied with the machine. Arrange the necessary appliances according to regulations or current norms to prevent water return to the network.

Pressure should be established between 0.1 MPa and 0.6 MPa (1-6 BAR). If pressures overpass such values, install the necessary corrective devices.

3.2 CONNECTION TO DRAINAGE

Drainage should be located lower to the machine level, at 150 mm (5.91 inches) minimum. It is convenient that the drainage pipe is of 30 mm (1.18 in) of interior diameter and with a minimum gradient of 3 cm (1.18 in) per meter (see figure).



3.3 ELECTRICAL CONNECTION

IT IS MANDATORY TO GROUND THE EQUIPMENT

To avoid possible discharges on individuals or damages to the equipment, the machine should be grounded pursuant local and/or national regulations as the case may be.

THE MANUFACTURER SHALL BE HELD HARMLESS IN CASE OF DAMAGES ARISING DUE TO THE LACK OF THE GROUND INSTALLATION

The machine should be placed in such a way as to allow a minimum space between the back and the wall to allow an easy access and without risks to the cable jack.

The machine is supplied with a 1.5 m. long cable. If the power cable is damaged, it must be replaced by a special cable or assembly to be provided by the manufacturer or the after-sales service. Such replacement must be performed by the qualified technical service.

Safeguard the base of the jack.

It is advisable to install a power switch and the appropriate electrical safety devices in accordance with local and/or national regulations in each case.

Voltage and tension are indicated in the nameplate and on the technical specifications of this manual. Variation on voltage above the 10% stated on the nameplate could result on damages or prevent the machine start-up.

3.4.- INSTALLATION OF EQUIPMENT ABOVE TANKS/BINS

The modular manufacturers must be installed on tanks or bins, following the instructions contained in this manual.

The strength and stability of the container-machine/s assembly must be verified, as well as the fixing of the elements.

The drain must be lower than the drainage area of the tank/bin and, the hose must always be in a descending position, NEVER ascending, (Figure IV).

IT IS IMPORTANT THAT THE WATER PIPE DOES NOT PASS BY OR NEAR HEAT SPOTS TO NOT LOSE ICE PRODUCTION

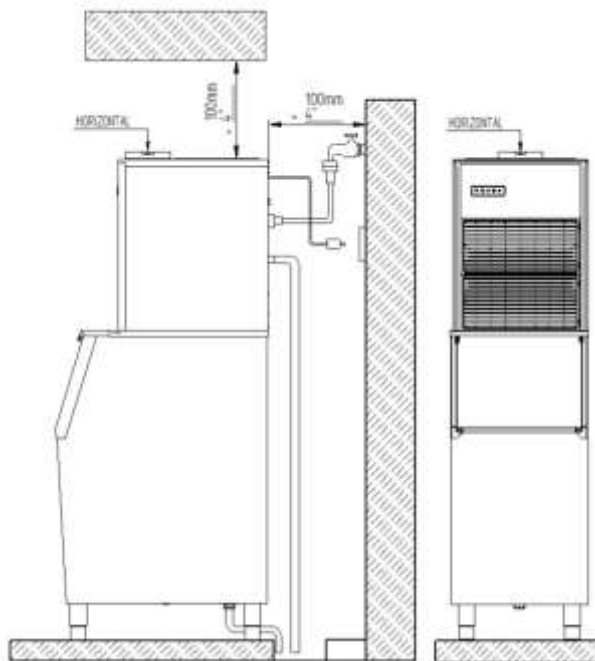

4. CONTROL PANEL

The outer panel is located on the front of the machine, in the upper left corner, and has 5 buttons:

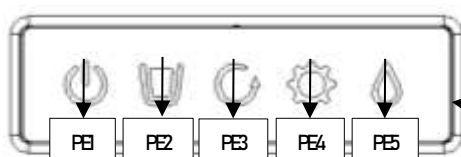

Figure V



Figure VI

4.1. PE1.- ON/OFF BUTTON

When turning on the rear switch of the machine, PE1 will be red, which means that the machine will be in the stand by mode. Pressing the PE1 button will enter the timing state and the LED will light up with a flashing blue. After the time period elapses, the LED will remain steady blue and the machine will start to work. If an alarm is detected in the machine, press the button for more than 3 seconds and the machine will restart.

4.2. PE2.- RESERVOIR FULL

This LED will light up when the machine has stopped when the reservoir is full.

4.3. PE3.- GEAR MOTOR ALARM

This alarm has two states.

In the first, the LED will remain flashing and the machine will perform a timing and will automatically resume. The machine will continue to operate in this state.

In the second state, the LED will remain steady and the machine will be stopped until a reset is performed.

4.4. PE4.-INTERNAL FAULT ALARM

This LED will remain on when an internal fault has occurred in the machine, or a blockage has occurred in the outlet. With this alarm, the machine will remain stopped.

4.5. PE5.- LACK OF WATER SUPPLY ALARM

This LED indicates that there is no water supply and therefore the machine is stopped because it cannot manufacture ice.

5. START-UP

5.1 PREVIOUS CHECKUP

- Is the machine leveled?
- Voltage and frequency are the same as those on the nameplate?
- Are the discharges connected and operating?
- ** If air condensed: Is the air circulation and its temperature appropriate?

	ROOM	WATER
MAXIMUM	43°C / 109.4°F	35°C / 95°F
MINIMUM	10°C / 50° F	5°C / 35°F

** Is water pressure appropriate?

MINIMUM	0.1 MPa (1 Bar)
MAXIMUM	0.6 MPa (6 Bar)

- The conductivity of the water must be at least 10 microSiemens

NOTE: In case input water pressure is higher that 0,6 MPa (6 Bar) install a pressure reducer.
THE FAUCETCONNECTION PRESSURE SHOULD NEVER BE REDUCED.

5.2. STARTING THE MACHINE

1. Connect to drinking water network. Open the water stopcock and check that there are no leaks.
2. Connect the machine to the electricity network. Turn the rear switch "ON".
3. The button on the control panel, PE1 (see Figure VI), must be lit red, when pressed, it will stay with a blue light flashing for 10 min.
4. After 10 minutes of the timer, the machine will start up and PE1 will remain with a steady blue light.
5. Check that there is no element that rubs or vibrates.
6. Check that it produces ice correctly. *It is normal that in the first instants a little water will drop instead of ice*.
7. Check that there is no alarm glowing on the control panel. In such case, restart the machine. If the problem persists, call the technical service.
8. Check that the ice bin stop sensor works. Move an object, or your hand, under the outlet of the ice dispenser. The blue led light should turn on and off. If necessary, clean the sensor as described in 6.4

6. MAINTENANCE AND CLEANING INSTRUCTIONS



You should wear rubber gloves and safety glasses when handling the ice machine cleaner or disinfectant.

All the ice that will be made during this procedure is not suitable for human consumption, so it must be melted or discarded.

* The maintenance procedures described in this manual are not covered by the warranty *

6.1. DESCALING PROCESS

Cleaning solution: Prepare a solution of an appropriate product for cleaning ice machines. Do not use hydrochloric acid. We recommend using ScaleKleen.

We recommend preparing a 10-liter solution according to the instructions of the manufacturer (ScaleKleen) with the total amount of product / water needed.

5 liters for hand washing and 5 liters for the water tank (D). Make more solution if necessary. For maximum effectiveness of the solution, use after dilution.

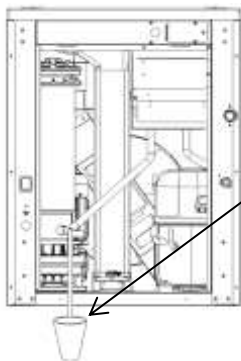

Drain water by removing the plug from the hose.

Figure VII

1. Stop the machine pressing PE1 button of the control panel, the PE1 button must be on red color.
2. Remove all the ice from bin.
3. Remove the back panel of the machine.
4. Remove the hose plug and drain the water into a container as shown in Image XVII.
5. Return the hose to its original position and put the plug in the hose again.
6. Remove the top panel.
7. Remove the water tank lid (A), O-ring (B) and ice outlet cover (C) and clean them by hand with cleaning solution.
8. Clean the fallen ice tube (E) with a brush also with the cleaning solution.
9. Place the ice outlet cover (C) in its original position.

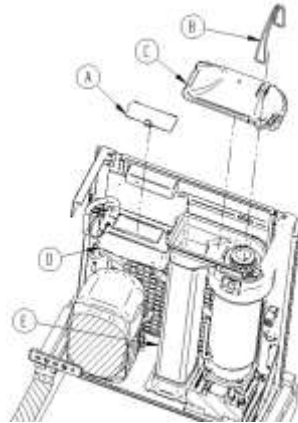

Figure VIII

10. For remove the ice of evaporator, active "Only gearmotor function", only will be running the gearmotor and the others components will be stopped. When the machine is stopped (PE1 button on the control panel is red), make a long press (over 7 seconds) on the PE1 button of the control panel until the five icons are flashing, so the gearmotor will start. Wait 2 or 3 minutes in order to remove the ice from evaporator and pour the cleaning solution as is indicated in the next step.
11. Pour the cleaning solution slowly into water tank (D) until it is finished. The solution will go overflowing through the drain, the electrodes inside of the water tank (D) are covered with the cleaning solution at the minimum level as shown in picture XVIII
12. The machine keeps working in "Only gearmotor function" with the five icons flashing and the machine stops automatically 30 minutes after to active this function in step 10, so the PE1 button will be red color. Go to next chapter for disinfection procedure.

6.2 DISINFECTION PROCEDURE

- **Disinfectant solution:** mix a disinfectant solution using an approved agent for food equipment. With sodium hypochlorite, to form a solution with 200 ppm free chlorine, dilute 35 ml of said 5.25% sodium hypochlorite solution (household bleach) with 10 liters of water.

5 liters for hand washing and 5 liters for the water tank (D). For maximum effectiveness of the solution, use after dilution. Make more solution if necessary.

1. Just after previous step 12 from descaling process, remove the hose plug and drain the water into a container as shown in the image XVII, return the hose to its original position and put the plug in the hose again.

2. Then, to disinfect the machine, active “only gearmotor function” and pour the 5 liters / 1.3 gal solution into the water tank (D) following the same procedure indicated in the descaling process (steps 10 and 11).
3. When disinfectant solution is finished, then wait to the machine stops automatically 30 minutes after active only gearmotor function.
4. Remove the hose plug and drain the water into a container as shown in the image XVII, return the hose to its original position and put the plug in the hose again.

Now, with the disinfectant solution destined to hand wash, clean the inside of the ice storage bin using a cloth or sponge. Go to next chapter for removing residues procedure.

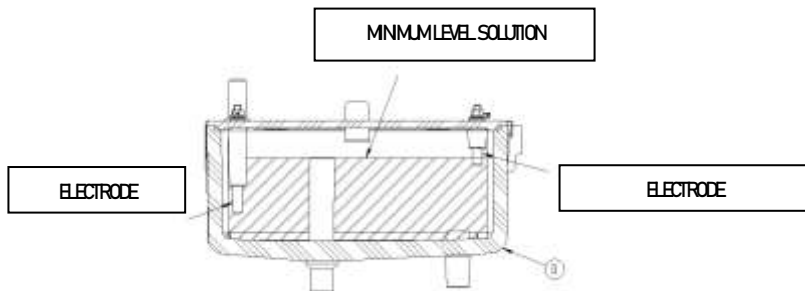
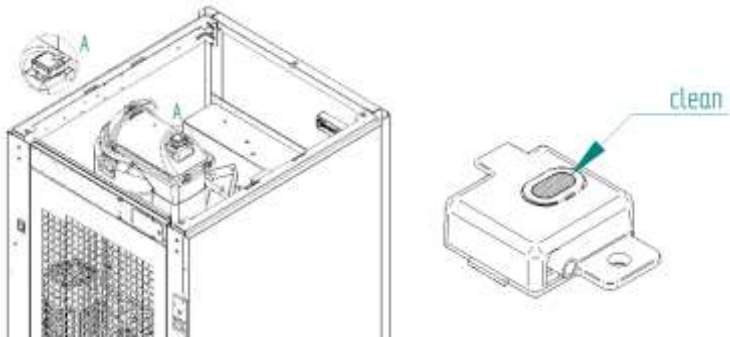

Figure IX

6.3 WASTE DISPOSAL PROCEDURE

1. To ensure that no debris remains in the machine, rinse the water tank lid (A) and the ice outlet lid (C) with water and place these items in their respective positions.
2. Also, rinse the ice downpipe (E) and the inside of the ice storage bin with the brush.
3. Place the back panel and the top panel in their original position.
4. Then, let the machine run for 30 minutes in the freeze cycle and melt or discard all the ice that is going to be made.

6.4 CLEANING STORAGE SENSOR



This must be done every time the machine is cleaned. Also in case the machine stops without the storage being full.

It is accessed through the back of the machine. Remove the sensor from its support by removing the fixing screw.

With a soft paper and alcohol clean the area of dark glass. NEVER USE ORGANIC SOLVENTS WHICH COULD DAMAGE THE PLASTIC SURFACE.

Reassemble and check operation: LED off indicates free sensor. Blue LED on indicates sensor activated (presence of ice).