

## REMOTE GIQ1100 INSTALLATION GUIDE

### STEP 1: EVAPORATOR AND CONDENSER UNIT LOCATION

#### COMPROBACION DE ACOMETIDAS CORRECTAS:

#### CHECKING THE PROPER CONNECTIONS:

- It needs an electrical supply, three phase unit (check label with power supply specifications). It comes with no electric cable. No cable connection between units.
- To connect the electric cable, open the side door.

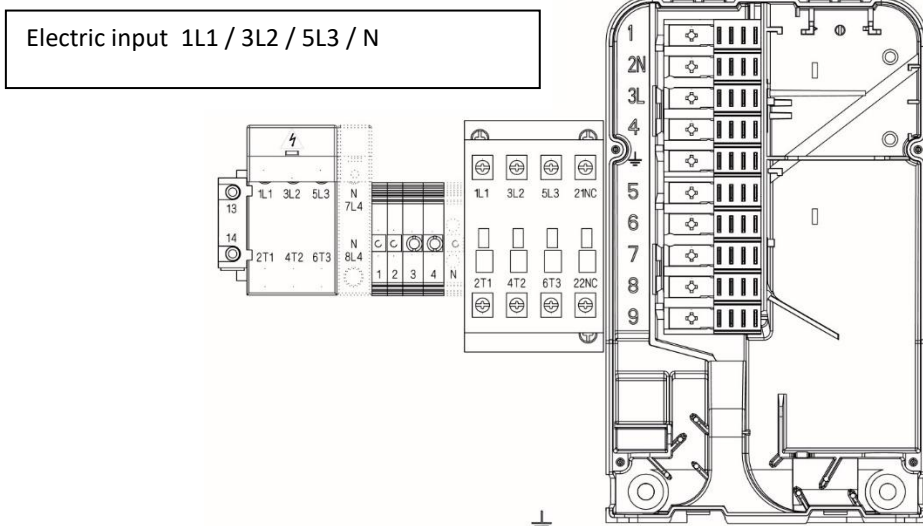
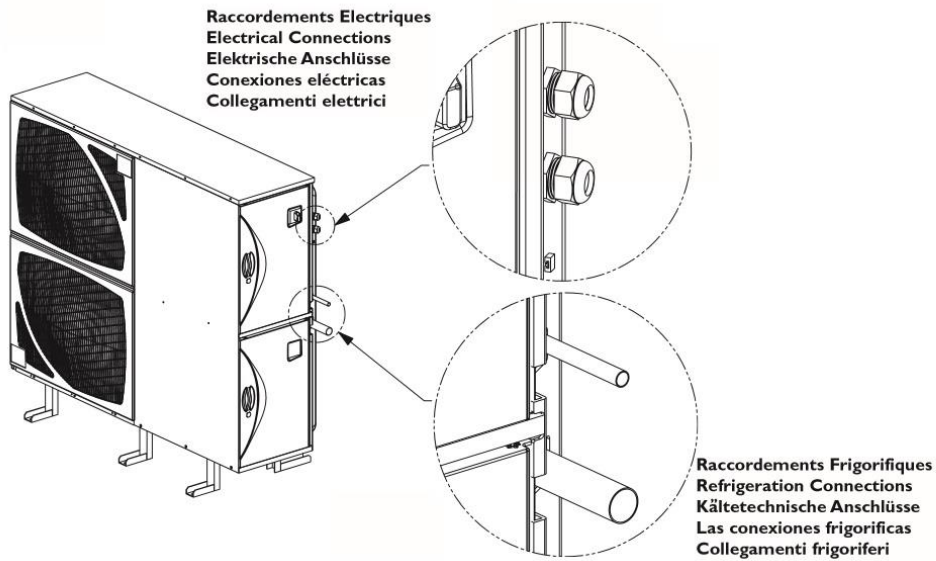

- Level the unit correctly.
- The unit can be mounted on the wall or on the floor.

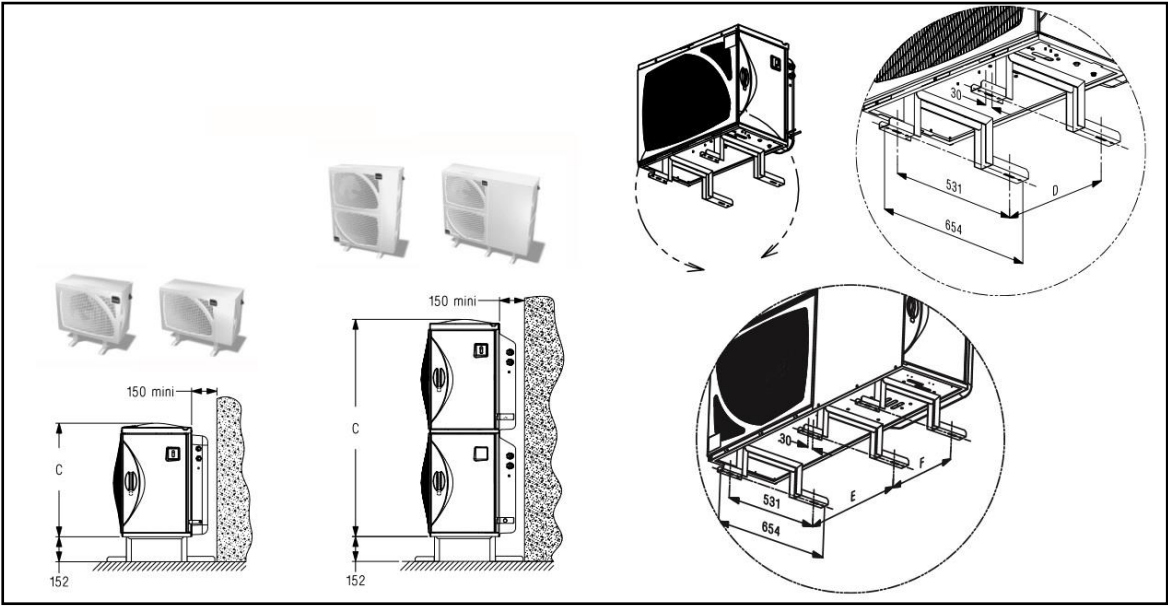

A	B	C	D	E	F
1108	574	1319	630		

- The unit can work outdoors.

**DIMENSION**

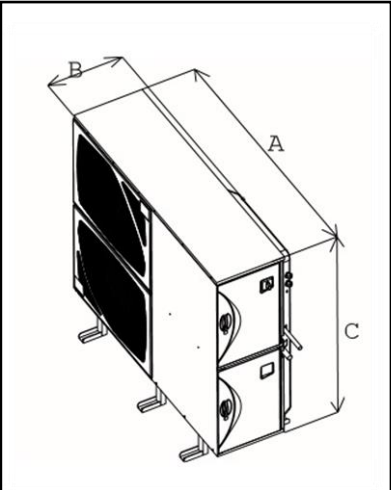

A	B	C
1108	574	1319

## GIQ1100:

- It needs an electrical supply (check label with power supply specifications).
- Water supply: it needs a water tap nearby. The unit comes with one or two water hose, 3/4" GAS connection.
- Drainpipe: The unit drains with the ice exit; it does not need a drain.
- Level the unit correctly.
- Keep in mind the ice exit, so it does not block, exit works by gravity.

## CENTRAL CROSS SECTION VIEW OF THE BASE VISTA DE LA BASE DESDE SECCIÓN CENTRAL

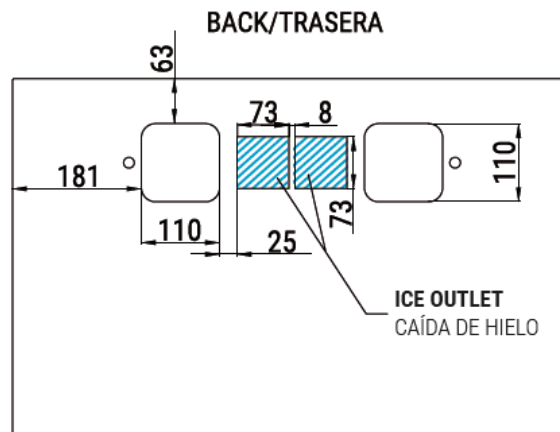

	Minimum value	Maximum value
Ambient temperature	5°C	43°C
Water temperature	5°C	35°C
Water pressure	1 bar	6 bar
Voltage deviation	-10%	6%

## STEP 2: REFRIGERATION CONNECTION BETWEEN BOTH UNITS

**CONDENSER UNIT:** To do the refrigeration installation, if needed it remove the lateral cover of the unit.

### CONDENSER UNIT PIPING CONNECTION

Suction pipe: 7/8"

Liquid pipe: 3/8"

- The condenser unit in the remote machines comes with the correct charge of R449A, to lengths up to 15 meters. For bigger distances, it might be necessary to increase the charge and / or increase the Refrigeration pipes. Please contact factory to know the changes for more than 15 meters.
- Always connect the remote condenser unit to the refrigeration pipes by welding; the condenser unit in the remote machines always comes with the refrigerant charged inside the liquid vessel.
- Try to do a clean installation, as straight forward as possible.
- If the condenser unit is below the evaporator level, it is not necessary to install a siphon to allow the oil to return to the condenser unit, due to the gravity effect. However, if a slope is used after the evaporator exit to avoid the liquid migration during the stops towards the compressor, it is advice to install a siphon at the evaporator exit, in the suction line.
- If the condenser unit is higher or equal to the evaporator unit, a siphon must be installed at the evaporator exit, in the suction line, one every 4 meters vertical, and one every 8 meters horizontal.

**GIQ1100 UNIT:** It is connected to the condenser unit with copper pipe.

## • STEP 3: INSTALLATION LEAKING TEST AND VACUUM

- Once the refrigeration pipes are weld and connected, a leaking test must be done to check that the line has no leakage in the nuts or the welding.
- After checking for leakages, a correct vacuum must be done. We advise to keep vacuum for around 24 hours.
- **ATTENTION:** Do not open the gas taps from the liquid vessel in the condenser unit (in remote units) before doing the vacuum, as the unit comes with refrigerant

## STEP 4: OPEN GAS AND LIQUID TAPS

- Once that everything is correctly installed and there are no leakages, and the vacuum has been done properly, open the liquid vessel on the condenser unit (only on remote machines), that comes with a refrigerant charge for 15 meters of distance between the remote condenser and the split unit. Open slowly the liquid tap and then the gas tap.

### PASO 5: START UP

- The unit can be turn on. It always have a time delay of 10 minutes, for security measures, after that it will start making ice. The condenser unit will automatically turn on when the liquid solenoid valve in the remote unit opens.