

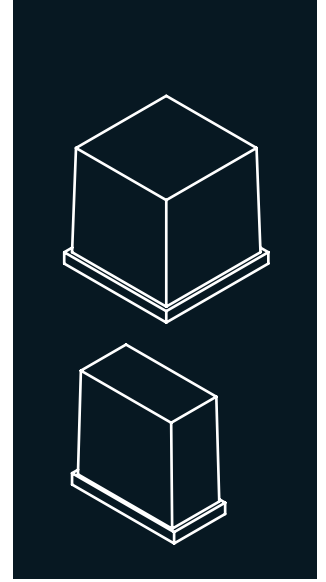











## SPIKA MS410 THREE PHASE 400 V / 50 Hz

### MODULARER EISWÜRFELBEREITER

#### EIGENSCHAFTEN

- ▶ PRODUZIERT HALBE UND VOLLE EISWÜRFEL
- ▶ HOCHLEISTUNGSFÄHIGER VERDAMPFER
- ▶ SPEZIELLER WASSERVERTEILER DER DIE ABNEHMEFFIZIENZ VERBESSERT
- ▶ EINFACHER ZUGANG DURCH ENTFERNEN DER PANELS MIT NUR 1 SCHRAUBENDREHER
- ▶ SMART ELECTRONIC BOARD STEUERT JEDEN PARAMETER IN DER MASCHINE UND ZEIGT DIE DIAGNOSE MÖGLICHER VORFÄLLE
- ▶ ENERGY STAR ZERTIFIZIERUNG DES NIEDRIGEN STROMVERBRAUCHS
- ▶ HOCHBESTÄNDIGER AUSSENRAHMEN AUS EDELSTAHL AISI 304



|               |  24 H |  10°C |  10°C |  21°C |  15°C |  |  |    |
|---------------|--|--|--|--|--|---|---|---|
|               |  | (Kg)   | (Kg)   | (Kg)   | (Kg)   | (mm)  | (mm)  | <b>SPIKA 6gr</b><br>23 mm (W) x 11 mm (D) x 26 mm (H)<br>DURCHSCHNITTSGRÖÖE   |
| SPIKA MS410 L |       | 424  | 405  | Breite   | 760  | Breite  | 836   | <br><b>SPIKA 12gr</b><br>26 mm (W) x 23 mm (D) x 26 mm (H)<br>DURCHSCHNITTSGRÖÖE |
| SPIKA MS410 W |       | 436  | 416  | Tiefe  | 620  | Tiefe   | 635   |   |
|               |  |  |  | Höhe   | 762  | Höhe  | 874   |   |

#### ZUBEHÖR

##### EINBEGRIFFEN



##### EMPFOHLEN



#### EMPFOHLENER VORRATSBEHÄLTER

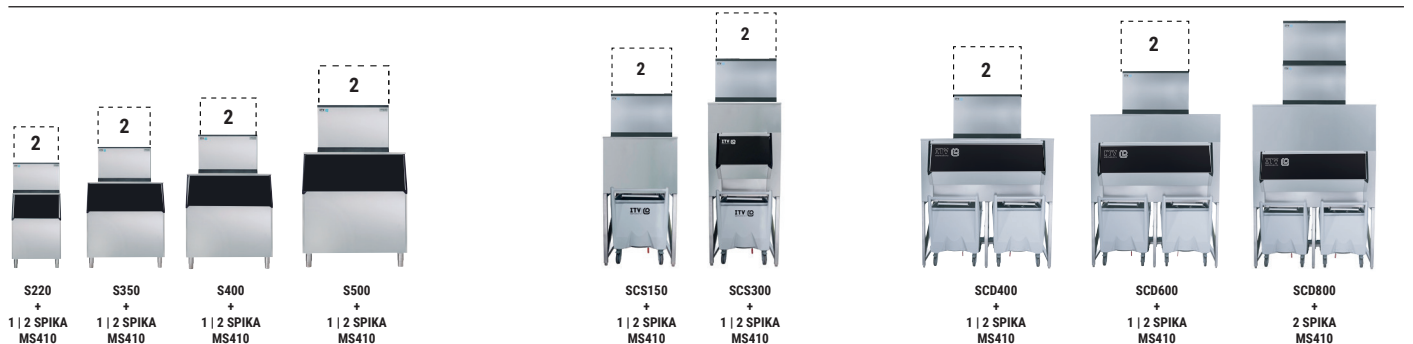

# TECHNISCHE DATEN

## SPIKA MS410

RECHTE SEITENANSICHT

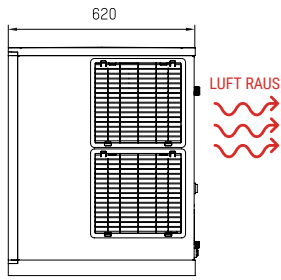

FRONTANSICHT

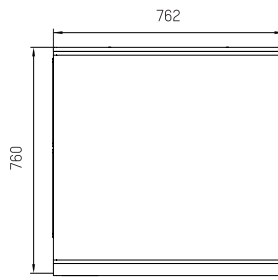

RÜCKANSICHT

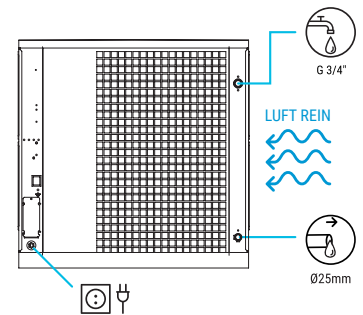

ZENTRALE QUERSCHNITTSANSICHT DER BASIS

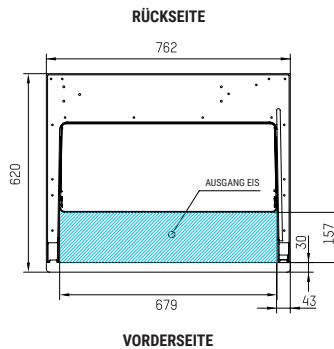

\* Alle Größen in mm.

## LEISTUNGEN

### PRODUKTION 50Hz

±10% V

10°C/43°C

5°C/38°C

1 bar/6 bar

400/800 Eiskegel/Zyklus

|         |    |    |
|---------|----|----|
| R 452 A |    |    |
| V       | Hz | ph |
| 400     | 50 | 3N |

**SPIKA MS410 LUFTGEKÜHLT**

| °C / °F    | 10° / 50° | 15° / 60° | 21° / 70° | 30° / 86° |
|------------|-----------|-----------|-----------|-----------|
| 10° / 50°  | 424       | 412       | 395       | 379       |
| 21° / 68°  | 413       | 405       | 386       | 368       |
| 32° / 90°  | 359       | 333       | 301       | 284       |
| 43° / 109° | 293       | 259       | 232       | 217       |

**SPIKA MS410 WASSERGEKÜHLT**

| °C / °F    | 10° / 50° | 15° / 60° | 21° / 70° | 30° / 86° |
|------------|-----------|-----------|-----------|-----------|
| 10° / 50°  | 436       | 423       | 406       | 389       |
| 21° / 68°  | 425       | 416       | 397       | 378       |
| 32° / 90°  | 369       | 342       | 310       | 291       |
| 43° / 109° | 301       | 266       | 239       | 223       |

## MODELLE

SPIKA MS410 L

SPIKA MS410 W

| ASHRAE KONDITIONEN (W) (BTU/h) | (W) 43°C | (n.) (mm <sup>2</sup> ) | SICHERUNG | 100 Kg (Kwh) | FULL   HALF (l/h) | WÄRME (W) (BTU/h) | (Kg) | (Kg) | (m <sup>3</sup> ) |
|--------------------------------|----------|-------------------------|-----------|--------------|-------------------|-------------------|------|------|-------------------|
| 11.185   38.185                | 1.540    | 3   2,5                 | 15        | 9,9          | 17   17           | 3.505   11.960    | 105  | 110  | 0,53              |
| 11.185   38.185                | 1.540    | 3   2,5                 | 10        | 9,9          | 110   110         | 3.505   11.960    | 105  | 110  | 0,53              |



ITV ICE MAKERS, S.L.  
POL. IND. SECTOR 13, AVDA. DELS HOSTALERS, 2  
46394 RIBARROJA DE TURIA, VALENCIA, SPAIN  
PHONE: +34 96 166 75 75 | FAX: +34 96 166 81 00  
info@itv.es | www.itv.es



SERVICE  
service@itv.es  
Skype: ITV.Service  
+34 961 667 639  
8:00AM | 7:00PM



Auf Teile und Lohn.  
Vorbehaltlich bestimmter  
Einschränkungen und  
Ausschlüsse.



VERTIKALES SYSTEM