



MS 220-400 / 30"

ITV
ICE makers



DESPIECE / REPUESTOS
EXPLODED VIEW / SPARE PARTS
EXPLOSIONSZEICHNUNG / ERSATZTEILE
VUE ÉCLATÉE / PIÈCES DÉTACHÉES
ESPLOSO / RICAMBI

AIR CONDENSER UNIT



MS 220-410 / 30"

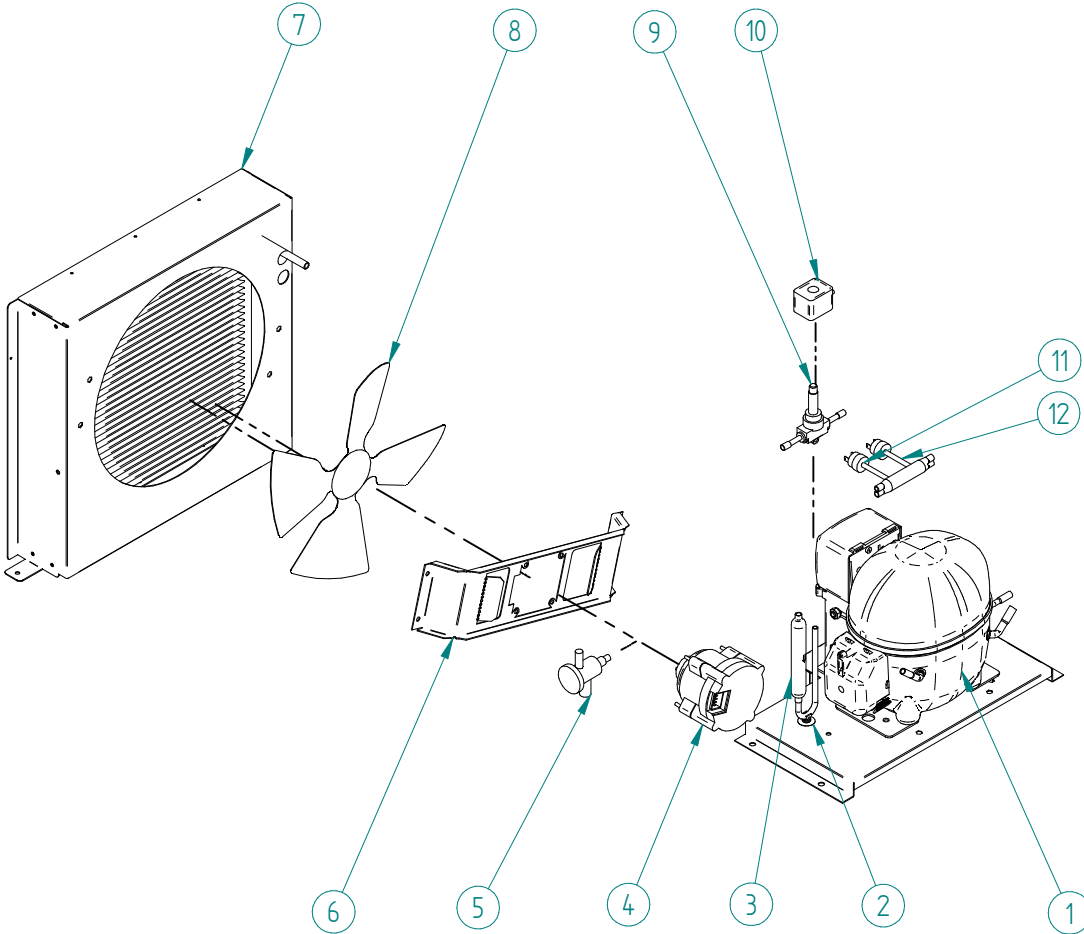

ITEM	DESCRIPTION	30"		
		MS 220	MS 410	
1	COMPRESSOR	220V/50HZ	31307	33348
		220V/60HZ	32762	N/A
		115V/60HZ	33423	N/A
2	PLASTIC CLIP 1/4"	3533		
3	DRIER FILTER	7896		
4	FAN MOTOR	220V/50-60HZ	32654A	N/A
		115V/60HZ	32655	N/A
	FAN MOTOR WIRE	220V/50-60HZ	32656	N/A
		115V/60HZ	32657	N/A
5	EXPANSION VALVE	31524		
6	FAN SUPPORT	6500U	N/A	
7	AIR CONDENSER	32156	35113	
8	FAN BLADE	6398	N/A	
9	HOT GAS VALVE - BODY	6396		
10	HOT GAS VALVE - COIL	220V/50-60HZ	5173	
		115V/60HZ	5414	N/A
11	HIGH PRESSURE SWITCH	31660E		
12	FAN CONTROL PRESSURE SWITCH	31160E		

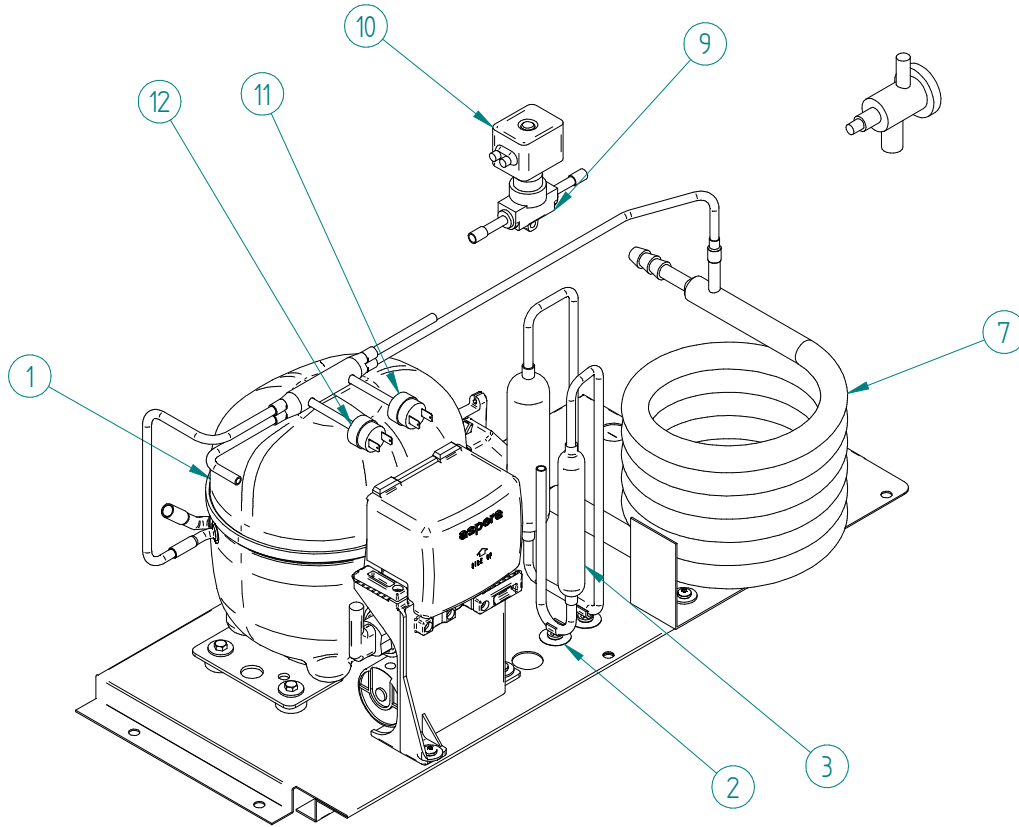

ITEM	DESCRIPTION	30"
		MS 220
1	PLASTIC CLIP 1/4"	3533
2	COMPRESSOR 220V/50-60HZ	31307
3	HIGH PRESSURE SWITCH	31660E
4	FAN CONTROL PRESSURE SWITCH	31160E
5	SEP PARTICLES	1570
6	HOT GAS VALVE - BODY	6396
7	HOT GAS VALVE - COIL 220V/50-60HZ	5173
8	EXPANSION VALVE	31524
9	CONDENSATOR	33671
10	DRIER FILTER	7896

ELECTRONIC BOX



MS 220-410 / 30"

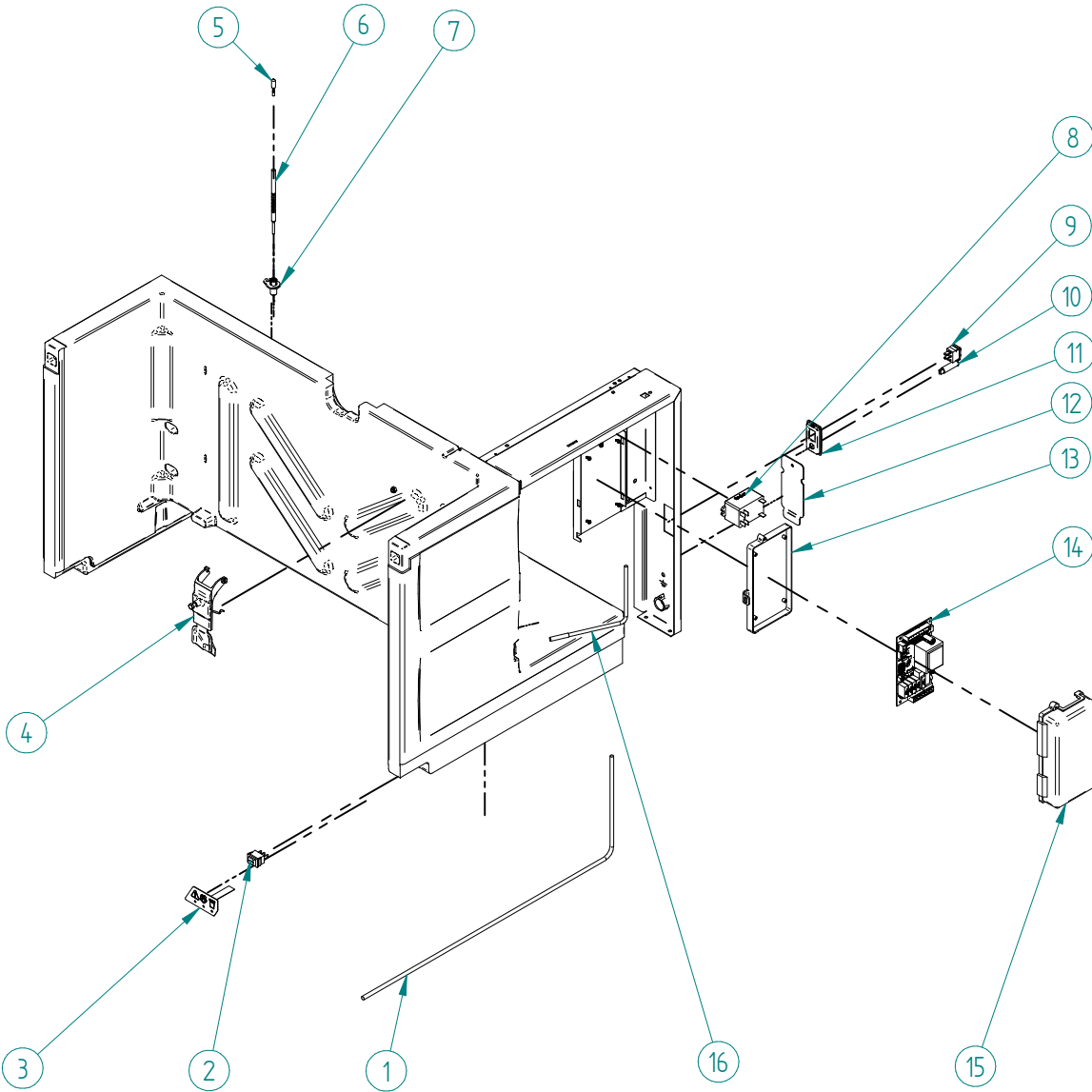

ITEM	DESCRIPTION	30"	
		MS 220	MS 410
1	DISPLAY WIRE 220V/50-60HZ 115V/60HZ	N/A	N/A
2	MAIN SWITCH	6161	
3	DISPLAY 220V/50-60HZ 115V/60HZ	N/A	N/A
4	THICKNESS ICE BLOCK SENSOR	6334B	
5	COMPRESSION RING	504	
6	ISOLATED WATER LEVEL SENSOR	30982	
7	SUPPORT WATER LEVEL SENSOR	8670	
8	RELAY FINDER 220V/50-60HZ 115V/60HZ	32503	N/A
9	SWITCH (ICE-STANDBY-WASH)	6161	
10	LED AZUL	32415	
11	MAIN SWITCH SUPPORT	32441	
12	JUNCTION BOX COVER 220V/50-60HZ 115V/60HZ	N/A	N/A
13	ELECTRIC BOX	2181	
14	ELECTRONIC BOARD 220V/50-60HZ 115V/60HZ	34642	N/A
15	ELECTRIC BOX COVER	30861	
16	SENSOR	6521A	

HYDRAULIC PARTS



MS 220-410 / 30"

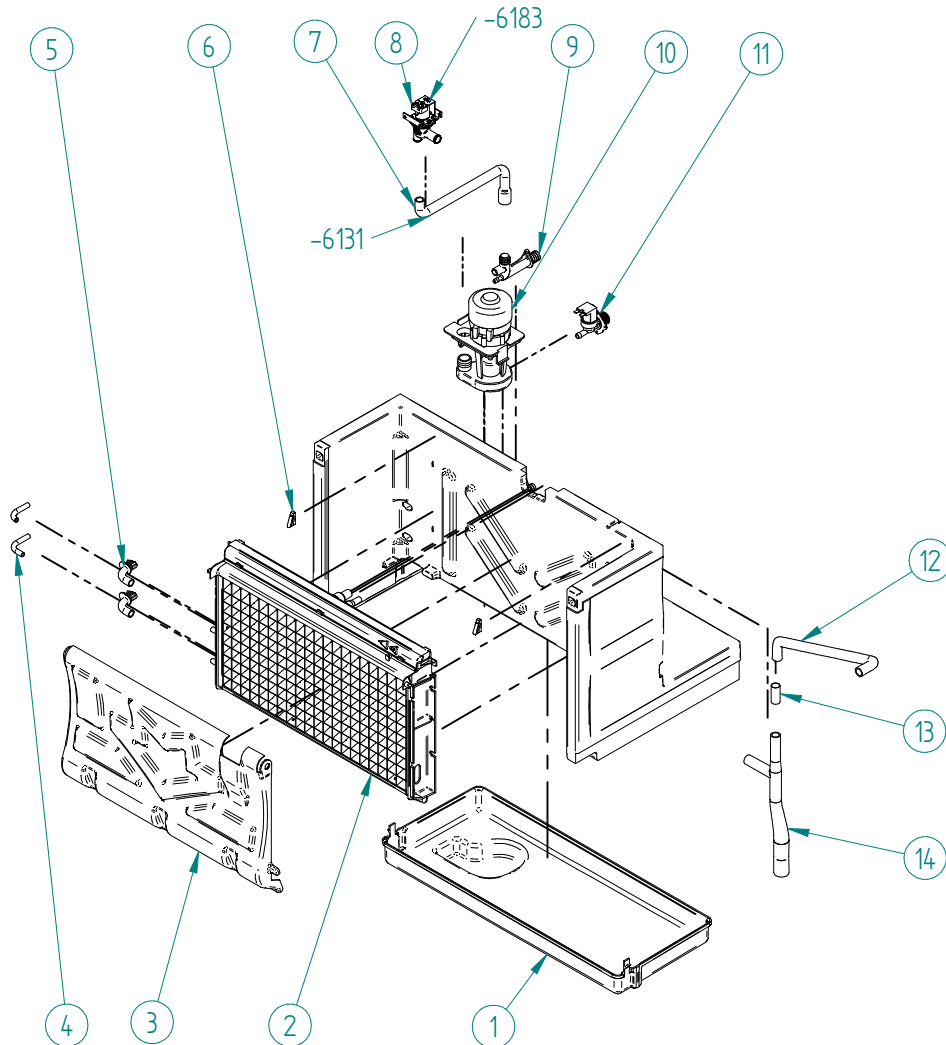

ITEM	DESCRIPTION	30"	
		MS 220	MS 410
1	WATER BIN	30413	
2	EVAPORATOR FULL DICE ASSY	6337A	
	EVAPORATOR HALF DICE ASSY	6338A	6340
3	CURTAIN	6081K	6080K
4	PIPE	3363	
5	PIPE PROTECTION	6132	
6	DISTRIBUTOR JOINT	6456A	
7	DRAIN TUBE	6131	
8	WATER DRAIN VALVE	220V/50-60HZ	6183
		115V-60HZ	6182 -
9	DRAIN FITTING	6206	
10	WATER PUMP	220V/50-60HZ	6509
		115V-60HZ	6508 -
11	INLET WATER VALVE	220V/50-60HZ	6980
		115V-60HZ	6984 -
12	UPPER WATER PUMP DISCHARGE TUBE	6129A	
13	WATER PUMP DISCHARGE TUBES JUNCTION	6526	
14	LOWER WATER PUMP DISCHARGE TUBE	6130A	

CABINET



MS 220-410 / 30"

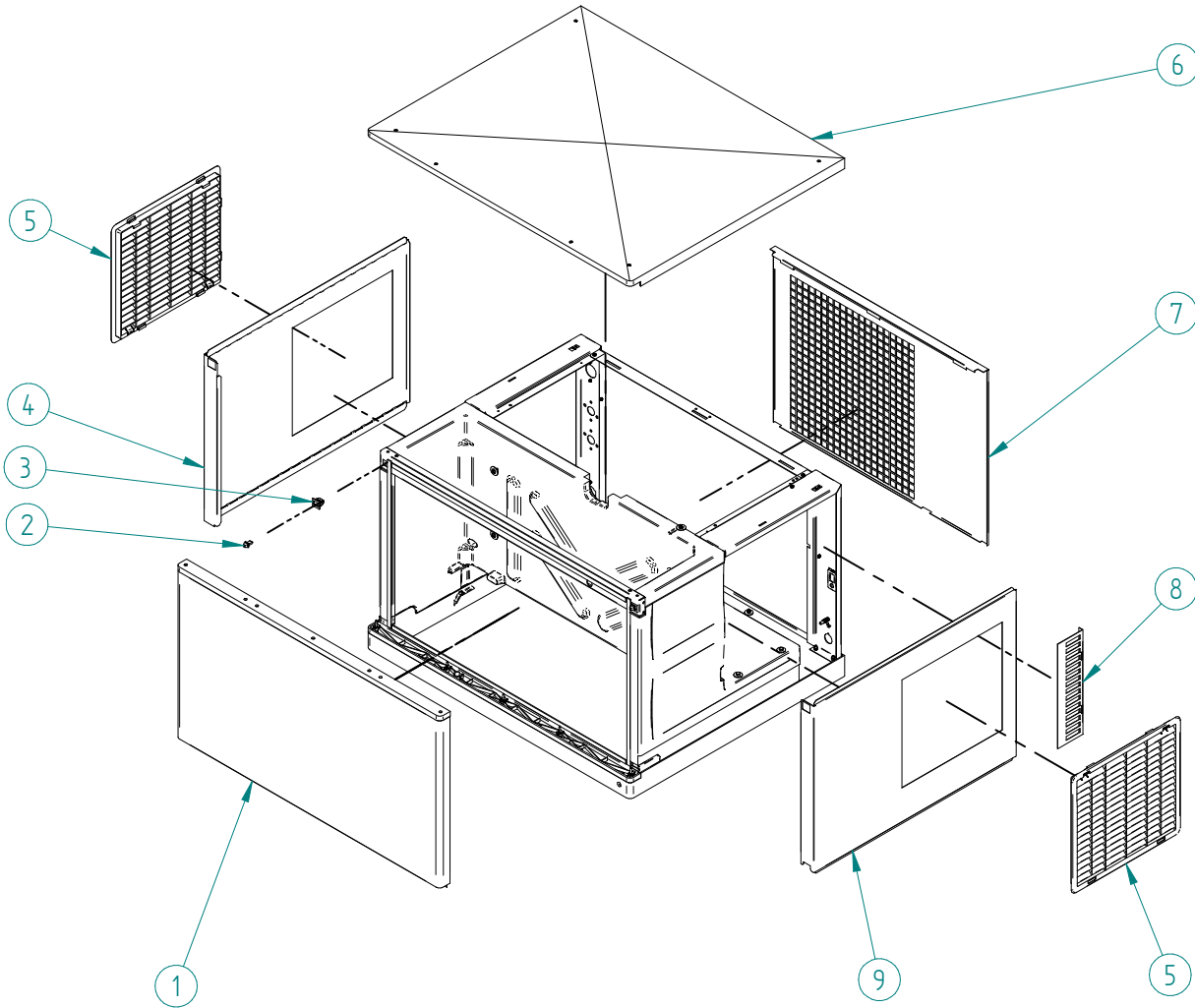

ITEM	DESCRIPTION	30"	
		MS 220	MS 410
1	FRONT PANEL	6269	6270
2	MALE PANEL CLIP	6181	
3	FEMALE PANEL CLIP	6180	
4	LEFT PANEL	6328	6330
5	SIDE LOUVER	6084	32835
6	TOP PANEL	6073	
7	REAR PANEL	6315U	6316
8	WIRE PROTECTION GRILL	32835	-
9	RIGHT PANEL	6327	6329