

SCALA 1000 REMOTE

THREE PHASE
400 V / 50 Hz

MODULAR FLAKE ICE MACHINE WITH REMOTE UNIT

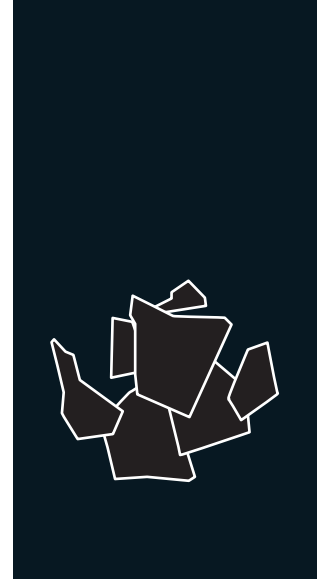

FEATURES CARACTÉRISTIQUES

- ▶ **PRODUCES COLD AND DRY FLAT FLAKES. FLAKE THICKNESS MAY BE ADJUSTED BETWEEN 1.5 MM AND 3 MM.**
PRODUIT DES ÉCAILLES PLATES, TRÈS FROIDES ET SÈCHES. L'ÉPAISSEUR PEUT SE RÉGLER ENTRE 1,5 MM ET 3 MM.
- ▶ **BASED ON A STATIC CYLINDER WHICH IS FREE FROM SWIVEL JOINTS (HELICAL REAMER) COUPLED WITH A MILLING TOOL THAT DETACHES THE ICE WITHOUT ANY STRAINED OR FORCED MOVEMENTS.**
FONCTIONNEMENT BASÉ SUR UN CYLINDRE STATIQUE SANS JOINTS TOURNANTS (HELICAL REAMER) ET AVEC UNE FRAISE QUI DÉCOLLE LA GLACE SANS TENSION NI EFFORTS.
- ▶ **THE MOST EFFICIENT EVAPORATOR OF THE MARKET, LESS ENERGY CONSUMPTION AND HIGHER ICE PRODUCTION.**
L'ÉVAPORATEUR LE PLUS EFFICACE DU MARCHÉ, MOINS DE DÉPENSES ÉNERGÉTIQUES, PLUS PRODUCTION DE GLAÇONS.
- ▶ **ELECTRONIC STOP SYSTEM / ELECTRICAL CONTROL PANEL / DRIVE DIRECT GEAR MOTOR / MAGNETIC DRIVE PUMP / LOW WATER SAFETY DEVICE.**
SYSTÈME D'ARRÊT ÉLECTRONIQUE / TABLEAU ÉLECTRIQUE DE RÉGLAGE / MOTORÉDUCTEUR D'ATTAQUE DIRECT / POMPE À ENTRAÎNEMENT MAGNÉTIQUE / SÉCURITÉ EN CAS DE MANQUE D'EAU.
- ▶ **STAINLESS STEEL SOLEPLATE.**
BÂTI EN ACIER INOXYDABLE.
- ▶ **CONTROLLERS TO DETECT: LOW WATER LEVEL, TEMPERATURE RISE DUE TO MOTOR OVERLOAD OR FULL VAT.**
CONTRÔLES POUR DÉTECTION : MANQUE DE NIVEAU D'EAU, AUGMENTATION DE TEMPÉRATURE POUR CAUSE D'EFFORTS EXCESSIFS DANS LE MOTORÉDUCTEUR OU DE REMPLISSAGE DU RÉSERVOIR.



	24 H	10°C (Kg)	15°C (Kg)	(mm)	(mm)	FLAKE ICE -7°C Ice Temperature
SCALA 1000 SPLIT		1.100	1.000	Width 1.050 Depth 750 Height 870	Width 1.150 Depth 970 Height 1.010	
RCU 1000	-	-	-	Width 1.108 Depth 574 Height 1.319	Width 600 Depth 1.200 Height 1.500	

ACCESSORIES ACCESSOIRES

INCLUDED



WATER INLET FILTER GASKET
JOINT DE FILTRE D'ENTRÉE D'EAU

WATER INLET HOSE
TUYAU D'ENTRÉE D'EAU

WATER OUTLET HOSE
TUYAU D'ÉVACUATION

OPTIONAL (NOT INCLUDED)

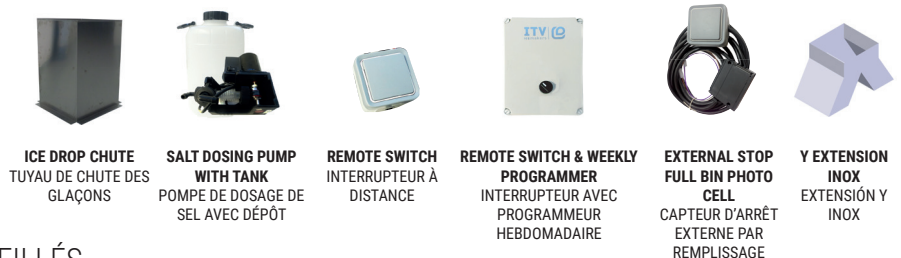

ICE DROP CHUTE
TUYAU DE CHUTE DES GLAÇONS

SALT DOSING PUMP WITH TANK
POMPE DE DOSAGE DE SEL AVEC DÉPÔT

REMOTE SWITCH
INTERRUPTEUR À DISTANCE

REMOTE SWITCH & WEEKLY PROGRAMMER
INTERRUPTEUR AVEC PROGRAMMEUR HEBDOMADAIRE

EXTERNAL STOP FULL BIN PHOTO CELL
CAPTEUR D'ARRÊT EXTERNE PAR REMPLISSAGE

Y EXTENSION INOX
EXTENSION Y INOX

RECOMMENDED BINS RÉSERVOIRS CONSEILLÉS



SCALA 1000 SPLIT

RIGHT SIDE VIEW
VUE LATÉRALE DROITE

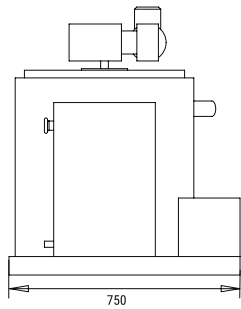

FRONTAL VIEW
VUE DE FACE

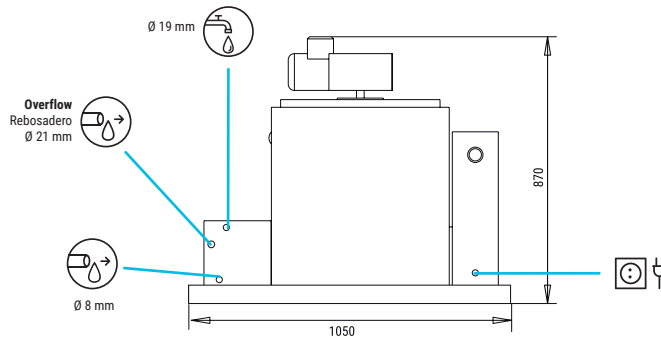

LEFT SIDE VIEW
VUE LATÉRALE GAUCHE

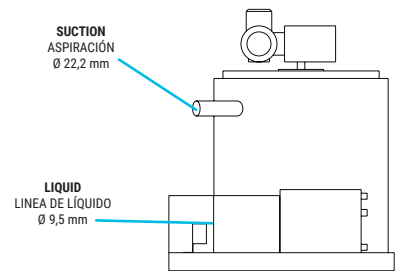

RCU 1000

CENTRAL CROSS SECTION VIEW OF THE BASE
VUE DE LA BASE DEPUIS LA SECTION CENTRALE

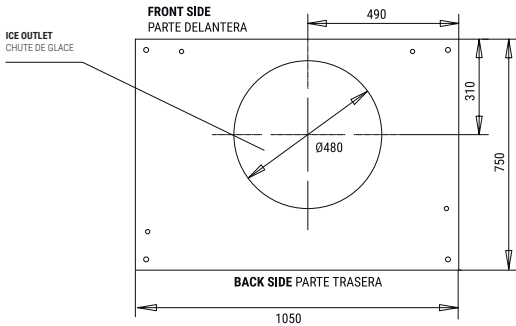

RIGHT SIDE VIEW
VUE LATÉRALE DROITE

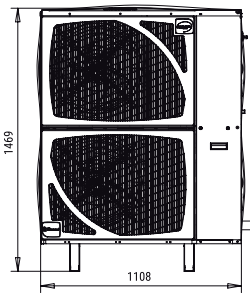

RIGHT SIDE VIEW
VUE LATÉRALE DROITE

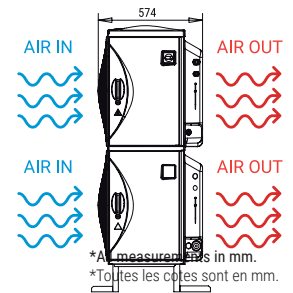

*All measurements in mm.
*Toutes les cotes sont en mm.

* All measurements in mm.
* Todas las cotas en mm.

OPERATING CONDITIONS CONDITIONS DE FONCTIONNEMENT

PRODUCTION 50Hz PRODUCTION 50 Hz

V	Hz	ph	SCALA 1000 REMOTE				SCALA 1000 REMOTE			
			10°	15°	21°	30°	10°	15°	21°	30°
±10% V			10°	1400	900	830	1023	1302	837	772
10°C/43°C			50°	1090	1000	875	1014	930	814	735
5°C/38°C			21°	1020	950	870	949	884	744	679
1 bar/6 bar			68°	860	780	650	800	725	605	558
			90°							
			99°							
			109°							

MODÈLES

Temp.EV. (°C)	ASHRAE CONDITIONS (W) (BTU/h)	(W) 43°C	(n.)	(mm ²)	FUSE	100 Kg (Kw/h)	(l/h)	HEAT REJECTED (W) (BTU/h)	(Kg)	(Kg)	(m ³)			
SCALA 1000 S	-22	5.500	18.767	190	3	2,5	16	7,5	41,6	-	-	170	200	1,13
RCU 1000	-	-	-	2.395	5	2,5	16	-	-	6.600	22.520	129	149	1,08



ITV ICE MAKERS, S.L.
POL. IND. SECTOR 13, AVDA. DELS HOSTALERS, 2
46394 RIBARROJA DE TURIA, VALENCIA, SPAIN
PHONE: +34 96 166 75 75 | FAX: +34 96 166 81 00
info@itv.es | www.itv.es



SERVICE SERVICE D'ASSISTANCE TECHNIQUE
service@itv.es
Skype: ITV.Service
+34 961 667 639
8:00AM | 7:00PM



Subject to certain limitations and exclusions. Only spare parts.
Sujet à limitations et exclusions. Pièces de rechange uniquement.

