

SCALA 10000 REMOTE

THREE PHASE
400 V / 50 Hz

MODULAR FLAKE ICE MACHINE WITH REMOTE UNIT

FEATURES CARACTÉRISTIQUES

- ▶ **PRODUCES COLD AND DRY FLAT FLAKES. FLAKE THICKNESS MAY BE ADJUSTED BETWEEN 1.5 MM AND 3 MM.**
PRODUIT DES ÉCAILLES PLATES, TRÈS FROIDES ET SÈCHES. L'ÉPAISSEUR PEUT SE RÉGLER ENTRE 1,5 MM ET 3 MM.
- ▶ **BASED ON A STATIC CYLINDER WHICH IS FREE FROM SWIVEL JOINTS (HELICAL REAMER) COUPLED WITH A MILLING TOOL THAT DETACHES THE ICE WITHOUT ANY STRAINED OR FORCED MOVEMENTS.**
FONCTIONNEMENT BASÉ SUR UN CYLINDRE STATIQUE SANS JOINTS TOURNANTS (HELICAL REAMER) ET AVEC UNE FRAISE QUI DÉCOLLE LA GLACE SANS TENSION NI EFFORTS.
- ▶ **THE MOST EFFICIENT EVAPORATOR OF THE MARKET, LESS ENERGY CONSUMPTION AND HIGHER ICE PRODUCTION.**
L'ÉVAPORATEUR LE PLUS EFFICACE DU MARCHÉ, MOINS DE DÉPENSES ÉNERGÉTIQUES, PLUS PRODUCTION DE GLAÇONS.
- ▶ **ELECTRONIC STOP SYSTEM / ELECTRICAL CONTROL PANEL / DRIVE DIRECT GEAR MOTOR / MAGNETIC DRIVE PUMP / LOW WATER SAFETY DEVICE.**
SYSTÈME D'ARRÊT ÉLECTRONIQUE / TABLEAU ÉLECTRIQUE DE RÉGLAGE / MOTORÉDUCTEUR D'ATTAQUE DIRECT / POMPE À ENTRAÎNEMENT MAGNÉTIQUE / SÉCURITÉ EN CAS DE MANQUE D'EAU.
- ▶ **STAINLESS STEEL SOLEPLATE.**
BÂTI EN ACIER INOXYDABLE.
- ▶ **CONTROLLERS TO DETECT: LOW WATER LEVEL, TEMPERATURE RISE DUE TO MOTOR OVERLOAD OR FULL VAT.**
CONTRÔLES POUR DÉTECTION : MANQUE DE NIVEAU D'EAU, AUGMENTATION DE TEMPÉRATURE POUR CAUSE D'EFFORTS EXCESSIFS DANS LE MOTORÉDUCTEUR OU DE REMPLISSAGE DU RÉSERVOIR.

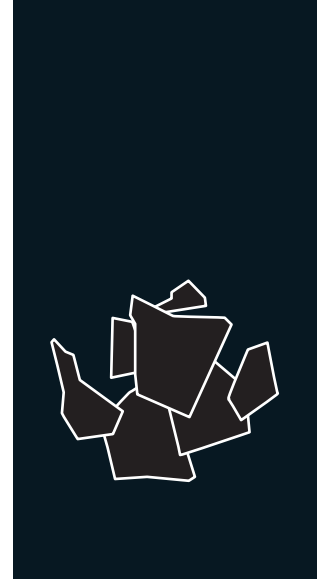

	24 H	10°C (Kg)	10°C (Kg)	21°C 15°C (Kg)	(mm)	(mm)	FLAKE ICE -7°C Ice Temperature
SCALA 10000 SPLIT		11.000	10.000		Width 1.850 Depth 1.150 Height 1.800	Width 1.910 Depth 1.230 Height 1.970	
RCU 10000		-	-		Width 3.600 Depth 1.150 Height 1.600	Width 3.800 Depth 1.470 Height 1.480	

ACCESSORIES ACCESSOIRES

OPTIONAL (NOT INCLUDED)



REMOTE SWITCH
INTERRUPTEUR À DISTANCE



REMOTE SWITCH & WEEKLY PROGRAMMER
INTERRUPTEUR AVEC PROGRAMMEUR HEBDOMADAIRE



EXTERNAL STOP FULL BIN PHOTO CELL
CAPTEUR D'ARRÊT EXTERNE PAR REMPLISSAGE

RECOMMENDED BINS RÉSERVOIRS CONSEILLÉS



SS422 + SCALA 10000 C02 SPLIT



SS623 + SCALA 10000 C02 SPLIT



SS732 + SCALA 10000 C02 SPLIT



SS1132 + SCALA 10000 C02 SPLIT

SCALA 10000 SPLIT

RIGHT SIDE VIEW
VUE LATÉRALE DROITE

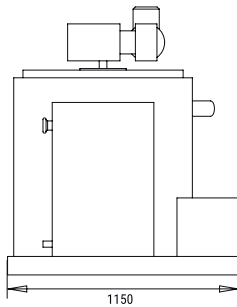

FRONTAL VIEW
VUE DE FACE

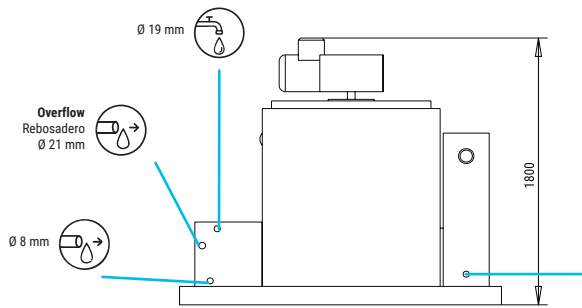

LEFT SIDE VIEW
VUE LATÉRALE GAUCHE

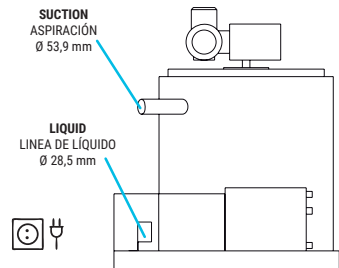

RCU 10000

CENTRAL CROSS SECTION VIEW OF THE BASE
VUE DE LA BASE DEPUIS LA SECTION CENTRALE

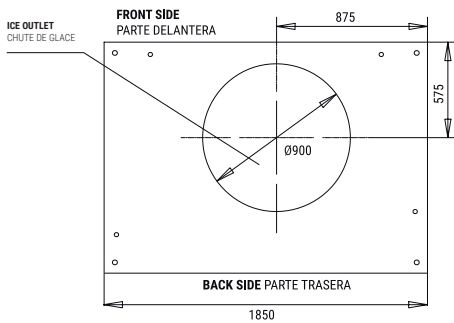

RIGHT SIDE VIEW
VUE LATÉRALE DROITE

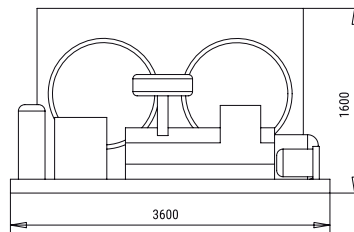

RIGHT SIDE VIEW
VUE LATÉRALE DROITE

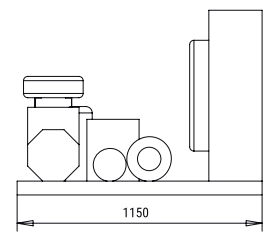

*All measurements in mm.
*Toutes les cotes sont en mm.

OPERATING CONDITIONS CONDITIONS DE FONCTIONNEMENT

PRODUCTION 50Hz PRODUCTION 50 Hz

±10% V

10°C/43°C

5°C/38°C

1 bar/6 bar

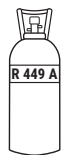

V	Hz	ph
400	50	3N

SCALA 10000 REMOTE

°C	10°	15°	21°	30°
°F	50°	60°	70°	86°
10°	11000	10400	9000	8250
50°				
21°	10800	10000	9750	7900
68°				
32°	10200	9450	8000	7200
90°				
43°	8700	7900	6500	6000
109°				

SCALA 10000 REMOTE

°C	10°	15°	21°	30°
°F	50°	60°	70°	86°
10°	11000	10400	9000	8250
50°				
21°	10800	10000	9750	7900
68°				
32°	10200	9450	8000	7200
90°				
43°	8700	7900	6500	6000
109°				

MODÈLES

	Temp.EV. (°C)	ASHRAE CONDITIONS (W) (BTU/h)	(W) 43°C	(n.)	(mm ²)	FUSE	100 Kg (Kw/h)	(l/h)	HEAT REJECTED (W) (BTU/h)	(Kg)	(Kg)	(m ³)
SCALA 10000 S	-22	55.000 187.668	435	3	1,5	60	6,8	416,6	-	-	1.400	-
RCU 10000	-	-	-	30.600	5	10	60	-	-	66.000 225.201	471	510 8,20



ITV ICE MAKERS, S.L.
POL. IND. SECTOR 13, AVDA. DELS HOSTALERS, 2
46394 RIBARROJA DE TURIA, VALENCIA, SPAIN
PHONE: +34 96 166 75 75 | FAX: +34 96 166 81 00
info@itv.es | www.itv.es



SERVICE SERVICE D'ASSISTANCE TECHNIQUE
service@itv.es
Skype: ITV.Service
+34 961 667 639
8:00AM | 7:00PM



Subject to certain limitations and exclusions. Only spare parts.
Sujet à limitations et exclusions. Pièces de rechange uniquement.

