



TECHNICAL MANUAL

NDP20 R290 RANGE

MODELS:

NDP 20

READ THIS MANUAL CAREFULLY, ESPECIALLY THE INSTALLATION AND MAINTENANCE SECTIONS. THE INSTALLATION OF THIS APPLIANCE MUST BE CARRIED OUT BY THE TECHNICAL ASSISTANCE SERVICE.

INDEX

1. <i>INTRODUCCIÓN</i>	4
1.1 WARNINGS.....	4
1.2. MACHINE RECEPTION	7
2. <i>INSTALLATION</i>	8
2.1. ICE MACHINE LOCATION	8
2.2. ICE MACHINE LEVELING	9
2.4. MINIMUM DISTANCE TO OBSTACLES.....	9
2.5. WATER SUPPLY CONNECTION	10
2.6. DRAIN CONNECTION.....	10
2.6.1. GRAVITY DRAINAGE	10
2.7. ELECTRIC CONNECTION	11
3.1. PRIOR CHECK.....	12
3.2. START UP	13
4. <i>COMPONENTS DESCRIPTION</i>	13
4.1 REFRIGERATION DIAGRAM.....	14
4.2 HYDRAULIC EQUIPMENT	15
4.3 ELECTRICAL EQUIPMENT.....	16
4.4. CONTROL BOARD	17
4.4.1 PCB CONNECTIONS.....	17
4.4.2 LED SIGNALLING: INPUTS	17
4.4.3 LED SIGNALLING: OUTPUTS	18
4.4.4 SIGNALLING LEDs	18
4.4.4 DIP SWITCHES SETTING	19
4.4.5 FUNCTIONS OF THE INTERNAL BUTTON ON THE PCB	20
5. <i>SEQUENCE OF OPERATION</i>	21
6- <i>ALARMS</i>	22
6.1 SAFETY HIGH PRESSURE SWITCH / THERMAL PROTECTOR.....	22
6.2 LONG HARVEST.....	22
6.3 ICE PRODUCTION CYCLE TIMEOUT	22
6.4. FAULTY TEMPERATURE PROBE.....	22
7. <i>MAINTENANCE AND CLEANING PROCEDURES</i>	23

7.1 CLEANING OF AIR CONDENSER	24
7.2 CLEANING THE WATER CONDENSER	24
7.3 CLEANING WATER DISTRIBUTOR AND INJECTORS	24
7.4 CLEANING THE ICE BIN AND EXTERIOR	25
7.5 WATER LEAKAGE CHECKING.....	25
7.6 CLEANING THE HYDRAULIC SYSTEM	25
7.7 MAINTENANCE TABLE	29
8.1 GENERAL QUESTIONS.....	30
9. <i>TECHNICAL DATA</i>	31
WIRING DIAGRAM.....	¡Error! Marcador no definido.
OTHER TECHNICAL INFORMATION	¡Error! Marcador no definido.

1. INTRODUCCIÓN

This manual has been created to provide the installer with information to carry out a correct installation and for the effective maintenance of the machine.

Furthermore, the user will find in the document a section referring to the cause of possible incidents, as well as complete information on their resolution.

Therefore, it is recommended to keep the manual in a safe place to resolve any questions related to the operation of the machine during its useful life.

1.1 WARNINGS

- The installation of this equipment must be carried out by the Technical Service.
- Connect only to a drinking water distribution network.
- Use the new hoses supplied with the appliance. Old hoses must not be reused.
- The socket must always be located in an accessible place.
- When positioning the appliance, make sure that the power cord is not trapped or damaged.
- Do not place multiple portable power outlets or portable power sources at the rear of the appliance.
- Always disconnect power to the machine before any cleaning or maintenance service.
- Any necessary change in the electrical installation for the proper connection of the machine must be carried out exclusively by qualified and certified professional personnel.
- Modifying or attempting to modify this machine is extremely dangerous and will void the warranty.
- The appliance must not be used by persons (including children) with reduced physical, sensory or mental capabilities, or lack of experience and knowledge, unless they have been given supervision or instruction.
- Connect only to potable water supply. This machine is not intended to be used outdoors or exposed to rain.
- The machine must be connected using the power cord supplied with the equipment. It is not intended to be connected to a fixed pipeline.
- To avoid danger due to instability of the appliance, it must be fixed in accordance with the instructions.

If the power cable is damaged, it must be replaced with a special mounting cable that will be supplied by the manufacturer or after-sales service. This replacement must be carried out only by a qualified technical service.

It is mandatory to connect the equipment to ground to avoid possible electric shocks to people or damage to the equipment. The machine must be grounded in accordance with local and/or national regulations. The manufacturer disclaims any responsibility in the event of damage occurring due to the lack of ground installation.

To ensure the proper functioning and efficiency of this equipment, it is very important to follow the manufacturer's recommendations, especially those related to cleaning and maintenance operations, which must only be carried out by qualified personnel.

ATTENTION: The intervention of unqualified personnel, in addition to being dangerous, can cause serious breakdowns. In case of damage, contact your dealer. We recommend always using original spare parts.

ITV reserves the right to make changes to specifications and design without notice.

WE REMIND YOU THAT MAINTENANCE AND CLEANING OPERATIONS ARE NOT INCLUDED IN THE WARRANTY AND THEREFORE, THEY WILL BE BILLED BY THE INSTALLER.

This sign indicates "Risk of Fire/Flammable Materials" due to the use of flammable refrigerant.



For this reason, the following warnings should be considered:

- Keep the openings for ventilation of the appliance casing or built-in furniture without obstructing it.
- Do not use mechanical devices or other means to accelerate defrosting, only those recommended by the manufacturer.
- Do not damage the refrigerant circuit.
- Do not use electrical devices inside the food compartments, unless they are recommended by the manufacturer.
- Explosive substances, such as aerosols with flammable propellant, must not be stored in this appliance.

In case of refrigerant leak:

- Do not generate a flame in the surroundings of the appliance.
- Do not turn on/off switches or connect/disconnect plugs in the area of the appliance.
- Do not use a direct flame.
- Immediately ventilate the area of the appliance by opening doors and windows.
- Call an authorized technical service.

Disposal of the ice machine: ITV encourages you to follow the regulations of each country regarding the ecological disposal of electrical and electronic devices such as this. The user who wants to dispose of this equipment must contact the manufacturer and follow the appropriate differentiated collection method for subsequent treatment.

1.2. MACHINE RECEPTION

Inspect the outer packaging. In case of damage, make the corresponding claim to the carrier. To confirm the existence of damage, unpack the machine in the presence of the carrier and note any damage to the equipment on the receipt document or transport document.

Always indicate the number and model of the machine. This number is printed in three places:

(1) **Packaging:** On the outside it contains a label with the serial number.



(2) **Exterior of the unit:** On the rear panel of the unit there is a label with the same characteristics as the previous one.

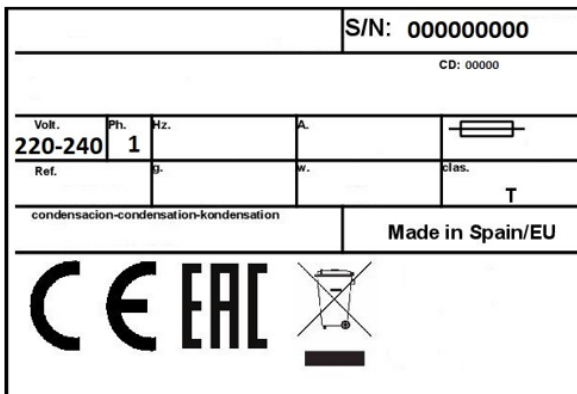

(3) **Nameplate:** On the back of the machine.

Check that the installation kit inside the machine is complete and includes:

Air condensed machine	Water condensed machine
Shovel	Shovel
¾ inch water inlet hose	2 x ¾ inch water inlet hose
22 mm drain hose	22 mm drain hose
1 filter gasket	1 filter gasket
User manual	User manual
Warranty and serial number	Warranty and serial number

CAUTION: All packaging elements (plastic bags, cardboard boxes and wooden pallets) must be kept out of the reach of children, as they are a source of potential danger.

2. INSTALLATION

2.1. ICE MACHINE LOCATION

This ice maker is not designed to be used outdoors. The ice maker should not be located next to ovens, grills, or other equipment that produces a lot of heat.

Incorrect installation of the equipment may cause damage to persons, animals or property, for which the manufacturer cannot be held responsible.

NDP20 machines are designed to operate at ambient temperatures between 10°C and 43°C (50°F and 109°F) and inlet water temperatures between 5°C and 35°C (41°F and 95°F).

Below the minimum temperatures there may be some difficulties in making the ice flakes. Above the maximum temperature, compressor life is shortened and output is substantially lower.

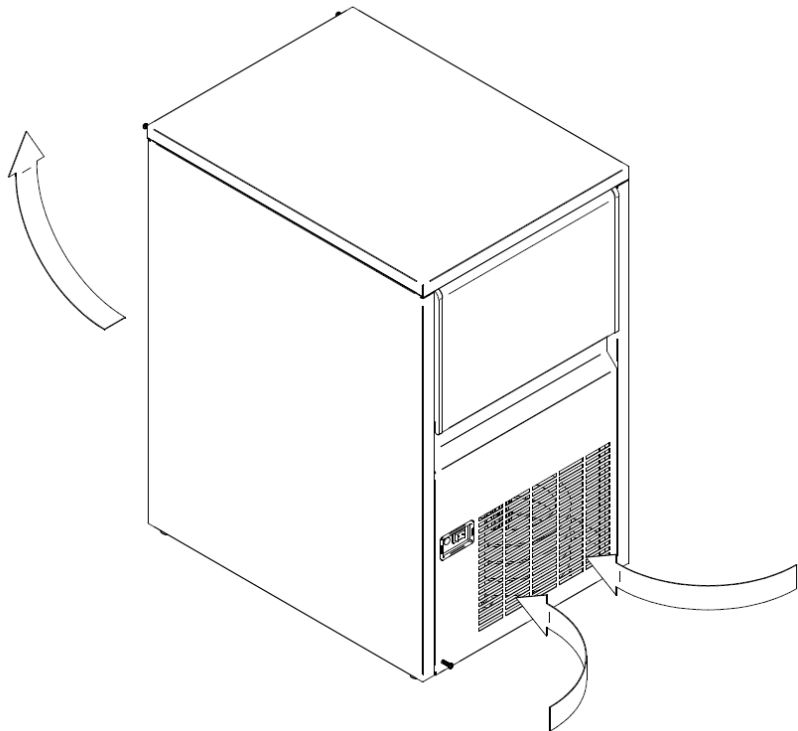

Airflow on compact air-cooled machines enters through the front grille, entering the right front, and exiting the rear. In addition, the unit is equipped with a rear ventilation grill. Do not obstruct the front grill with any object.

If the frontal ventilation is not sufficient, the outlet is totally or partially obstructed or due to its location it receives hot air from another appliance, we recommend, if it is not possible to change the location of the machine, INSTALLING A CONDENSED MACHINE BY WATER.

IT IS IMPORTANT THAT THE WATER PIPES DO NOT PASS NEAR HEAT SOURCES SO AS NOT TO LOSE ICE PRODUCTION.

The location should allow sufficient clearance for the water, drain, and electrical connections at the rear of the icemaker.

2.2. ICE MACHINE LEVELING

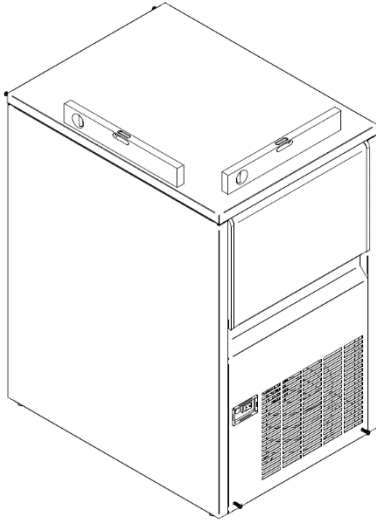

Use a level on the top of the ice maker to ensure the equipment is perfectly level.

Screw the leveling feet into the bottom of the ice maker as far as they will go. Place the machine in its final position.

Use a level on top of the ice maker.

2.4. MINIMUM DISTANCE TO OBSTACLES

The machines expel hot air through the grilles, which must be discharged into the room and not accumulate. This is particularly important for the air expelled from the rear of the machines: a space of at least 10cm must be left up to the wall, allowing the air to flow from behind and out so that there is a renewal of this, avoiding the formation of hot air pockets in that area that could reduce the machine's ice production and even activate its protection against excessive temperature and stopping it.

Connection diagram:

The location should allow sufficient clearance for water drainage and electrical connections at the rear of the ice machine.

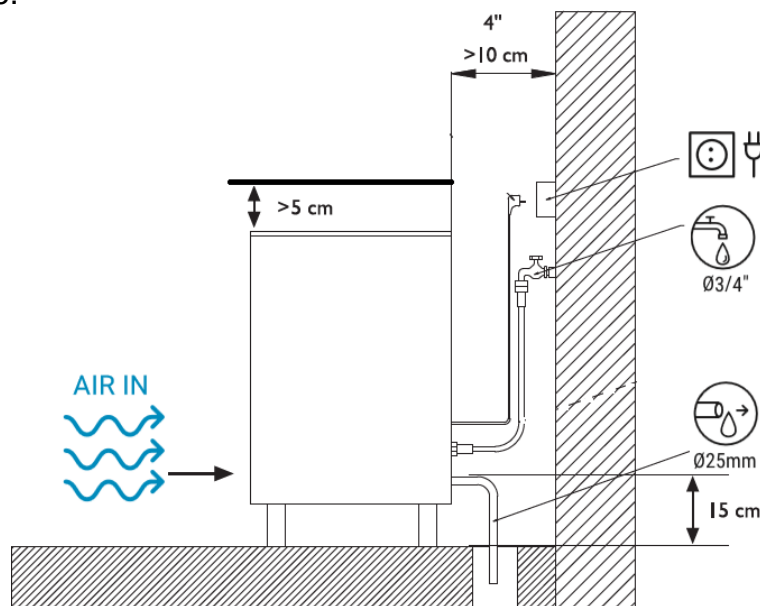

2.5. WATER SUPPLY CONNECTION

The quality of the water supplied to the ice maker will influence the time between cleanings and ultimately the life of the product (mainly on water-cooled units). It will also have a notable influence on the appearance, hardness and flavor of the ice.

Local water conditions may require water treatment to inhibit scale formation and improve flavor and clarity. If you are installing a water filtration system, refer to the installation instructions supplied with the filtration system.

The pressure must be between 0.1MPa and 0.6MPa (1 and 6 bar). If the pressure exceeds these values, install a pressure regulator.

The water connection must be dedicated (only equipment hooked to the water line).

In water condensing machines, two water inlets are provided, one dedicated to the water condensing system and the other to the water supply for ice making. The water outlet is common for both circuits.

ATTENTION: The machine must be connected to the pipeline with adequate backflow protection in accordance with current national and local regulations.

2.6. DRAIN CONNECTION

2.6.1. GRAVITY DRAINAGE

The drain must be located lower than the level of the machine, at least 150mm.

It is advisable that the drain hose be 30mm in inner diameter and with a minimum slope of 3cm/meter.

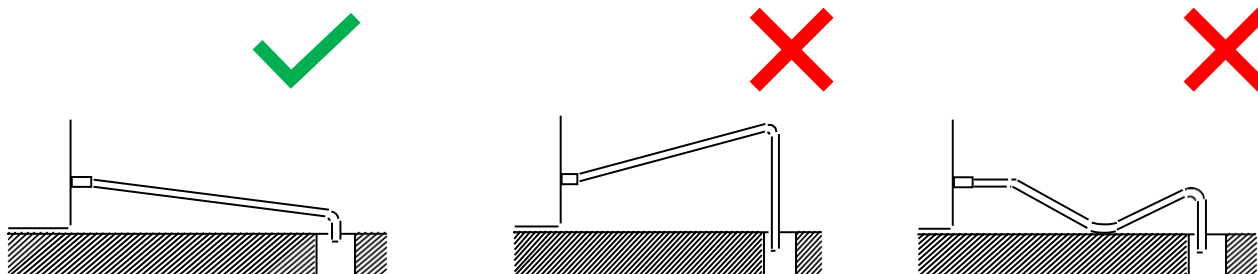

2.7. ELECTRIC CONNECTION

- It is mandatory to connect the equipment to ground. To avoid possible electric shock to persons or damage to the equipment, the machine must be grounded in accordance with local and/or national regulations, as applicable.
- The manufacturer disclaims any responsibility in the event that damage occurs due to the lack of ground installation.
- The positioning of the appliance must ensure that the electrical supply is not damaged or choked.
- Do not install portable multiple sockets or other portable power sources on the rear of the appliance.
- The machine is supplied with a 1.5 m long cable.
- If the power cable is damaged, it must be replaced with a special mounting cable that will be supplied by the manufacturer or by the after-sales service. This replacement must be carried out only by a qualified technical service.
- The machine should be positioned so that there is a minimum of space between the back and the wall to allow easy and safe access to the cord plug.
- It is advisable to install a remote switch to completely disconnect the machine.
- Protect the outlet. Install appropriate switches, fuses and differential protector.

ATENCIÓN: El aparato requiere una fuente de alimentación independiente de capacidad adecuada. Consulte las especificaciones eléctricas en la placa de características. Si no se utiliza una fuente de alimentación independiente de la capacidad adecuada puede haber daños en los componentes internos o en el cableado. Esto podría provocar la generación de calor o un incendio.

The voltage is indicated on the nameplate and in the technical specifications section of this manual. A voltage variation greater than 10% indicated on the nameplate may cause damage or prevent the machine from starting.

3. PRIOR CONTROL AND START-UP

3.1. PRIOR CHECK

- a) Is the machine leveled?
- b) Do the voltage and frequency match those on the nameplate?
- c) Are the drains connected and working?
- d) Are the ambient temperature and water temperature maintained in the following range?

	ATMOSPHERE	WATER
<i>MAXIMUM</i>	43°C/109.4°F	35°C/95°F
<i>MINIMUM</i>	10°C/50.0°F	5°C/41°F

- e) Is the water pressure adequate?

<i>MINIMUM</i>	0.1MPa (1 bar)
<i>MAXIMUM</i>	0.6 MPa (6 bar)

NOTE: In case the inlet water pressure is greater than 6 bar, install a pressure reducer.

3.2. START UP

Once installation instructions have been followed (ventilation, site conditions, temperatures, water quality, etc.), proceed as follows:

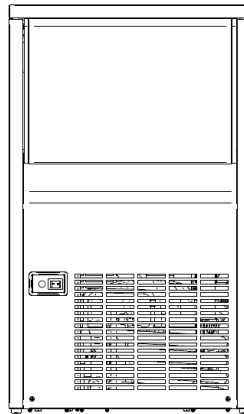

1. Open the water inlet. Verify the no existence of leakages.
2. Open the door and remove the protection elements on the shield.
3. Verify that the curtain moves freely.
4. Connect the machine to the power supply.
5. Push the switch on the machine front side.
6. Verify that there are no vibrations or frictions on the elements.
7. The machine has a timer governing startup, allowing for water to be recharged for the production cycle.
8. Check the cubes after two cycles; they should be uniform in shape. If they do not come out correctly, or the unit does not make ice, contact an authorized service technician.

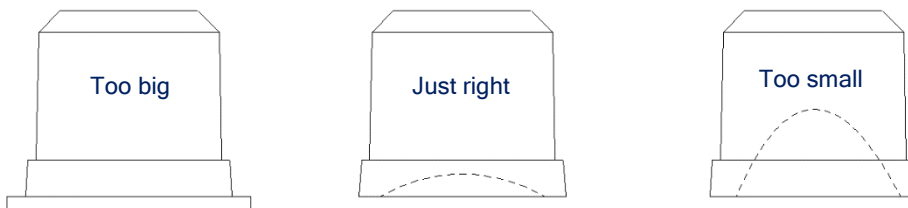

9. The unit produces ice until the bin is full, using a stop sensor. When the ice is removed from the bin, the unit will once again produce ice.

WARNING: this switch does not disconnect all the voltage inside the machine. Disconnect from the mains before handling.

4. COMPONENTS DESCRIPTION

4.1 REFRIGERATION DIAGRAM

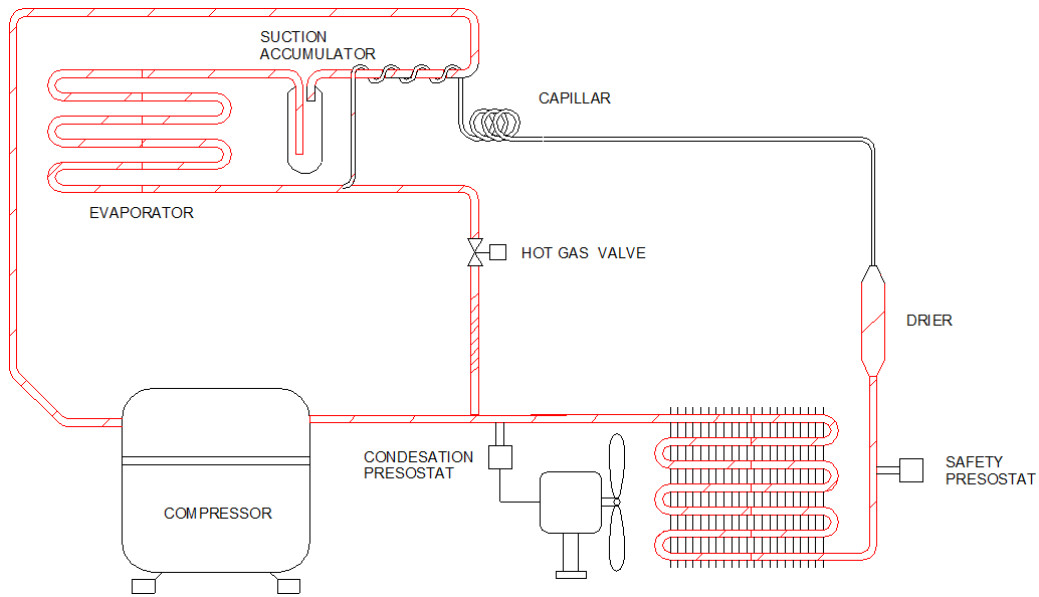

Esquema frigorífico de condensación por aire

It consists of the following components:

1. **Compressor:** It sucks in gases at low pressure from the cold source and supplies them with pressure and temperature to be discharged to the hot source.
2. **Condenser:** receives the gases from the compressor where they give up heat to the mean (air or water).
3. **Evaporator:** An evaporator that receives the refrigerant still with liquefied particles where they evaporate by absorbing heat from the mean. It is an isobaric and isothermal process.
4. **Capillar**
5. **Hot gas valve:** is a valve that is installed between the compressor discharge line (high pressure hot gas) and the low pressure line.
6. **Drier:** filters and dehydrates the coolant.
7. **Safety pressure switch (high pressure):** Stops the machine, in case a pressure higher than this value is reached:

R290 → OFF 25 bar (362 psi)

8. **Condensing pressure switch:** Controls the fan (air condensation) or valve (water condensation) to keep the high pressure at the stipulated level:

R290 → OFF 11.5 - ON 13.5 bar (167- 196 psi).

4.2 HYDRAULIC EQUIPMENT

- **Water inlet valve.** Controlled by the control board; supplies water to the tank.
- **Pump**→ Hydraulic machine that sets water in motion, providing flow and pressure. They have a rotor with blades inside a casing and an electric motor that drives them. They can be submerged or aerial.
- **Injectors:** These are the terminal orifices that project the water into the moulds of the horizontal evaporators. They can be sprayers or flat showers.
- **Distributors:** Sets of injectors arranged inserted in a duct. Aligned and spaced with the "pitch" of the evaporator to which they spray.

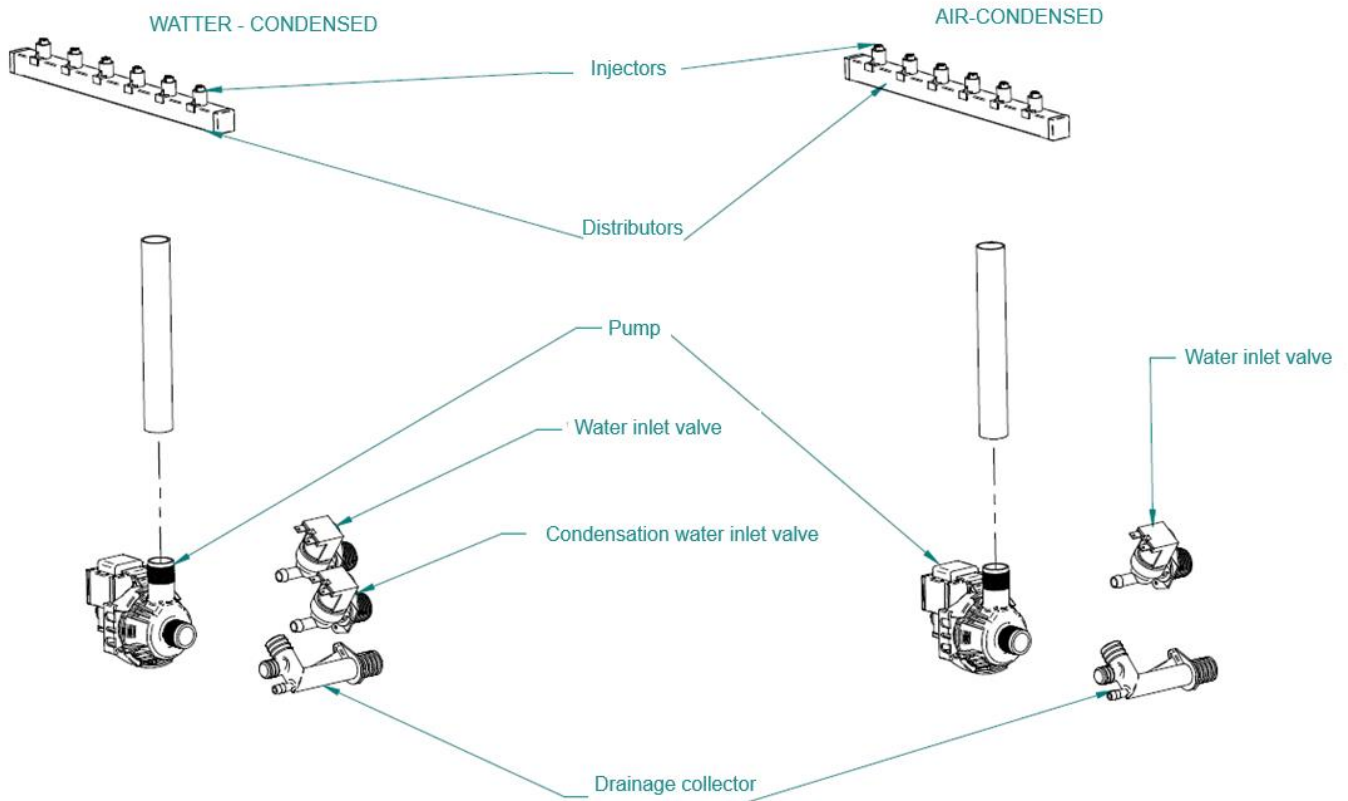

4.3 ELECTRICAL EQUIPMENT

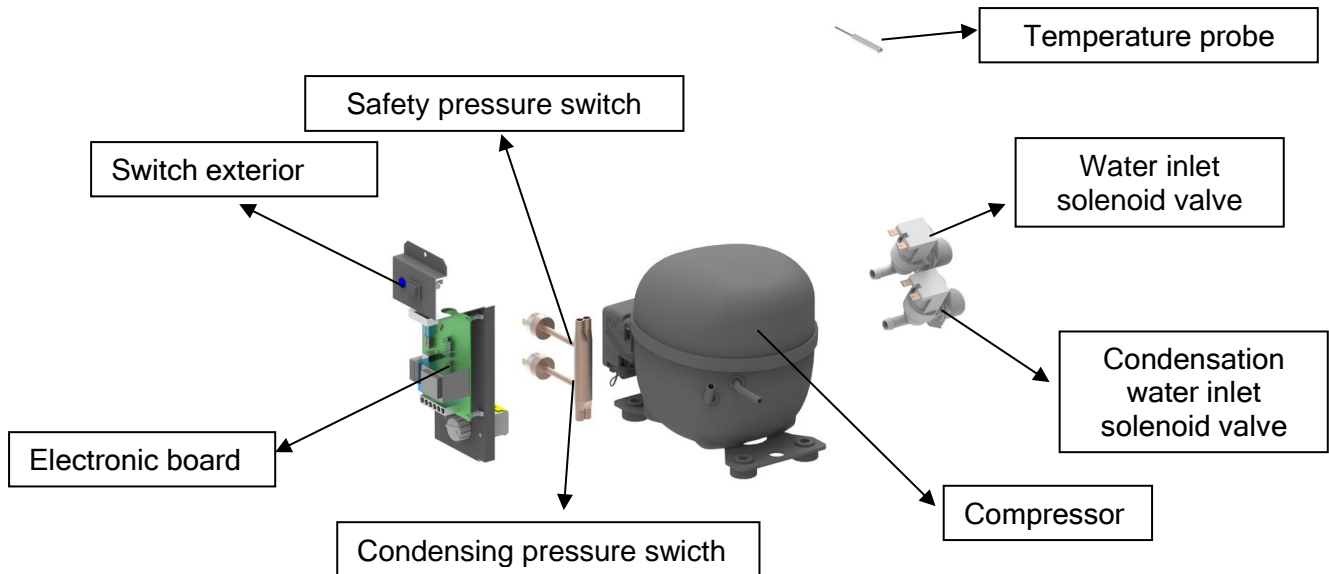

- **Switch exterior** → Can disconnect the power supply to the equipment or a point in the control system that guarantees the disconnection of the electrical elements.
- **Electronic board (PCB control)** → Control board that receives input signals, manages them and returns outputs, normally by activating relays.
- **Water inlet solenoid valve (EW)** → Input fresh water for the new cycle.
- **Condensation water inlet solenoid valve (EW)** → Provides the water inlet for use in the condenser (ONLY ON WATER CONDENSED MACHINES).
- **Safety pressure switch (Pt)** → In the event of reaching the set pressure (25 bar), it stops the machine completely and sets it in alarm.
- **Condensing pressure switch (Pc)** → Starts or stops the fan or water inlet to maintain the set high pressure.
- **Temperature probe** → Temperature probe types are sensors that measure the temperature of a medium by converting a physical quantity into an electrical signal.
- **Compressor** → It sucks in gases at low pressure from the cold source and supplies them with pressure and temperature to be discharged to the hot source.

4.4. CONTROL BOARD

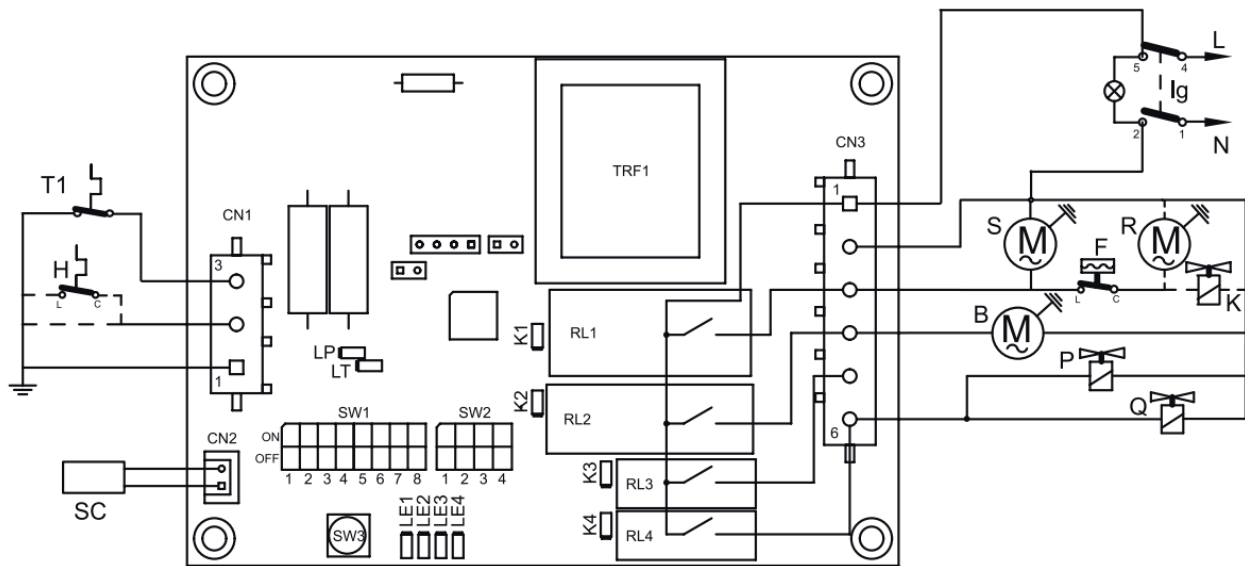

Symbol	Description
SC	Cycle NTC probe
T1	Stock thermostat
P	Water valve
Q	Hot gas valve
S	Compressor
B	Water pump
F	Condensing pressure switch
R	Fan
K	Condensation valve (water-condensing only)
H	Thermal protector (water)/Safety pressure switch (air)
lg	General switch

4.4.1 PCB CONNECTIONS

Symbol	Description
CN1	Inputs: Stock thermostat and safety pressure switch connections
CN2	Cycle NTC probe
CN3	Outputs: Connections: Compressor, pump, e/W-valve, hot gas valve

4.4.2 LED SIGNALLING: INPUTS

Red LED color with active signal.

LED ON	Description
LP	(H) Thermal protector (water condensed only)
LT	(T1) Stock thermostat

4.4.3 LED SIGNALLING: OUTPUTS

Orange LED color with active signal.

LED ON	Description
K1	(S+R) Compressor, fan
K2	(B) water pump
K3	(P) Valve/w
K4	(Q) Hot gas valve

4.4.4 SIGNALLING LEDs

The following tables describe the signals provided by the different LEDs on the control board.

4.4.3.1 Input LEDs

The input LEDs are positioned next to each of their corresponding inputs. Orange LED color with active signal.

4.4.3.2 Output LEDs

The output LEDs are positioned next to their corresponding relays. Orange LED color with active signal.

4.4.3.3 Status LEDs. Normal work (fixed LEDs)

There are four additional orange LEDs that signals machine status (continuous):

Continuous orange LED	LE1	LE2	LE3	LE4
Start up delay	X			
Harvest $t < t_g$	X		X	
Harvest $> t_g$			X	
Ice cycle $T > T_c$	X	X		
Ice cycle $T < T_c$		X		
Full bin				X

4.4.3.4 Status LEDs. Alarm (Flashing LEDs)

The following table defines the alarm states of the machine, which can be differentiated with the following flashing of the status LEDs:

Flashing Orange LED	LE1	LE2	LE3	LE4
Thermal protector / Safety pressure switch	X			
Ice cycle timeout 60' (T evaporator>Tc)		X		
Harvest cycle timeout 5' (T evaporator<Tg)			X	
Faulty temperatura probe				X

4.4.4 DIP SWITCHES SETTING

The following table describes the functionality of the micro-switches that the table has, that is, the work options that the combinations of these can provide:

DIP Switches	Descripción
SW1 MICRO 8	Tc - Evaporator temperature for timer start. ON-12°C-OFF -8°C.
SW2 MICRO 1	Determines the temperature at which the evaporator must be at for the start of the harvest. Tg (Hot valve temperature). ON+4°C-OFF 0°C.
SW2 MICRO 2	Manual or automatic thermal protector reset (water condensed only). ON = AUTO OFF=MANUAL.
SW2 MICRO 3	ON. Timeout alarms operation activated.
SW2 MICRO 4	ON
SW3 BUTTON	Press the button to change the state of the machine cycle. Production – harvest/Harvest – Production. Pressing the SW3 push button and changing the switch to position (I) will change the status of the machine to cleaning cycle.

The following table shows the default intensity configuration in each of the possible combinations allowed by the switches on the control board:

SWITCH 1 (SW1)				TF (MIN)	SWITCH 1 (SW1)			TW (SEG)
1	2	3	4		5	6	7	
OFF	OFF	OFF	OFF	6	OFF	OFF	OFF	40
ON	OFF	OFF	OFF	8	ON	OFF	OFF	60
OFF	ON	OFF	OFF	10	OFF	ON	OFF	80
ON	ON	OFF	OFF	12	ON	ON	OFF	100
OFF	OFF	ON	OFF	14	OFF	OFF	ON	120
ON	OFF	ON	OFF	16	ON	OFF	ON	140
OFF	ON	ON	OFF	18	OFF	ON	ON	160
ON	ON	ON	OFF	20	ON	ON	ON	180
OFF	OFF	OFF	ON	22	<div style="border: 1px solid black; padding: 10px; text-align: center;"> <p>The factory default will be indicated on the machine's wiring diagram, located on the cover of the electrical panel.</p> </div>			
ON	OFF	OFF	ON	24				
OFF	ON	OFF	ON	26				
ON	ON	OFF	ON	28				
OFF	OFF	ON	ON	30				
ON	OFF	ON	ON	32				
OFF	ON	ON	ON	34				
ON	ON	ON	ON	36				

4.4.5 FUNCTIONS OF THE INTERNAL BUTTON ON THE PCB

Function depends on the unit status:

- Start up timer: Finish initial delay y passes to ice production stage
- Ice production. Switches to harvest
- Harvest. Switches to Ice production

Wash cycle activation

Keep pressed the button while switching on main front switch. Wash cycle is activated and only the water recirculation pump is running. There is a maximum time for this cycle of 30 min. After this time, pump stops.

Wash cycle is finished by switching off main power.

Read cleaning and sanitizing instructions for proper usage of this function.

5. SEQUENCE OF OPERATION

Once you connect the machine there is a time delay of 30" during which the water valve is activated to ensure the water tray is filled. Compressor, pump will be off.

Once the time is up, it continues with a harvest cycle and the compressor starts.

When the evaporator reaches the Tg temperature of +0°C /+4°C according to DIP setting SW2, the hot gas time (40") starts. Variable according to DIP SW1 (MICRO 5,6,7).

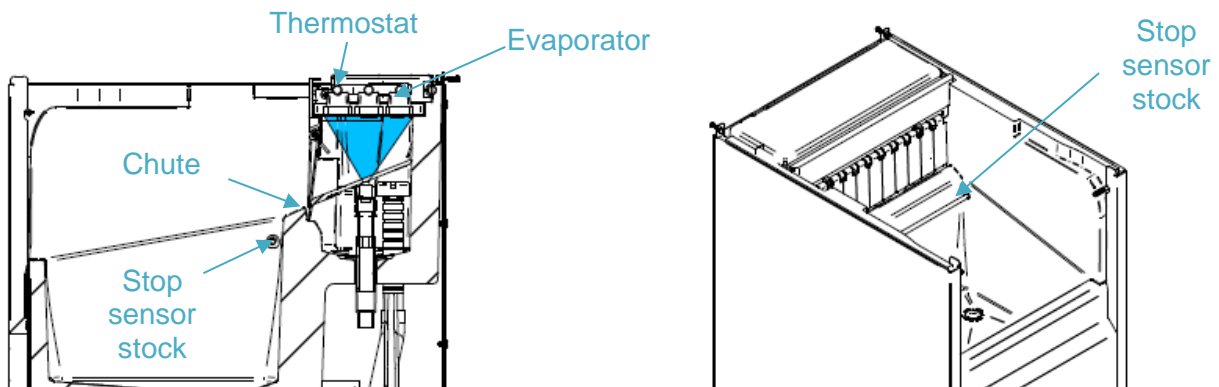

At the end of the hot gas time, the production time starts. When the evaporator reaches a temperature (Tc) of -12°C /-8°C depending on DIP SW1-8 configuration, the production time starts 10'. Variable between 6-36' according to DIP SW1 (MICRO 1,2,3,4).

Once the manufacturing time is over, the machine will start a new cycle by removing the formed ice.

At the beginning of each Harvest cycle, the PCB checks if the Thermostat is open or close. Once the ice bin is full and the ice cubes cover the thermostat tube, the contact open, so when the harvest begins, the machine will stop until the contact of the thermostat close again. When it close, it starts with a harvest cycle and then it will continue with the production cycle again.

6- ALARMS

They detect operational malfunctions. They are indicated with the flashing status Leds LE1-4. During some alarms a second operation retry attempt is carried out and if repeated again, the machine will stop. Signaling should be indicated since the first failure occurs. If the second retry attempt is ok, the signaling will switch off.

In case that a machine stop has been caused by alarm, the reset is done by switching OFF and ON the main switch. If the dip-switch 11 OFF, time alarms are not to be followed.

6.1 SAFETY HIGH PRESSURE SWITCH / THERMAL PROTECTOR

When the pressure contact (P) trips, instantly, all outputs switch over to off position.

When it is closed again, there are two possibilities:

- Dip-switch 10 OFF. Manual reset. The machine remains stopped until reset to Initial start-up.
- Dip-switch 10 ON. Automatic reset. The machine check pressure switch status every 30 min.
When closed, the machine will continue at the position where it was.

Signalling: Flashing LE1.

6.2 LONG HARVEST

If the harvest time is longer than 5 min., the harvest is interrupted, switching over to the production cycle. If the same happens again at the next harvest, the machine will stop.

Signalling: Flashing in LE3.

6.3 ICE PRODUCTION CYCLE TIMEOUT

If during the production cycle, evaporator temperature probe has not reached the set temperature T_c in more than 60 min, the machine will stop until reset.

Signalling: Flashing in LE2.

6.4. FAULTY TEMPERATURE PROBE

If PCB detects that evaporator temperature probe is broken or unconnected, the machine will stop.

Signalling: Flashing in LE4.

Probe type is NTC and resistance value must be 10k Ω at 25°C.

7. MAINTENANCE AND CLEANING PROCEDURES

It is the User's responsibility to keep the ice machine and ice storage bin in a sanitary condition.

Ice machines also require occasional cleaning of their water systems with a specifically designed chemical. These chemical dissolves mineral build up that forms during the ice making process.

Sanitize the ice storage bin as frequently as local health codes require, and every time the ice machine is cleaned and sanitized.

The ice machine's water system should be cleaned and sanitized at least twice a year.

CAUTION: Do not mix Ice Machine Cleaner and Sanitizer solutions together.

WARNING: Wear rubber gloves and safety goggles when handling Ice Machine Cleaner or Sanitizer.

WARNING: Unit should always be disconnected during maintenance/cleaning procedures.

RUBBER GLOVES AND SAFETY GOGGLES SHOULD BE WORN WHEN HANDLING ICE MACHINE CLEANER OR SANITIZER.

7.1 CLEANING OF AIR CONDENSER

1. Disconnect the power supply of the machine.
2. Close the water inlet valve or the faucet.
3. Remove the front grid by removing the two screws placed at front side (see figure).
4. Clean condenser using a vacuum cleaner, soft brush or low pressure air. Clean from top to bottom, not side to side. Be careful not to bend the fins of the condenser.
5. Open the water inlet valve or tap.
6. Switch on the power supply to the machine.

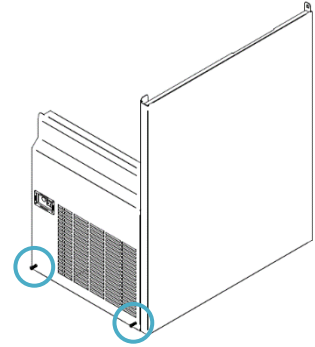

7.2 CLEANING THE WATER CONDENSER

1. Disconnect the machine.
2. Disconnect the water inlet or close the faucet.
3. Disconnect the water inlet and outlet from the condenser.
4. Prepare a solution at the 50% of phosphoric acid and distilled or demineralized water.
5. Make the solution circulate through the condenser. (The solution is more effective if hot – between 35°C [95°F] and 40°C [104°F]).

7.3 CLEANING WATER DISTRIBUTOR AND INJECTORS

1. Remove the curtain. (Take advantage to clean it with Calklin or some non-aggressive product, rinse, clean with bleach and rinse under the tap).
2. Remove the ice fall grill. (Clean it just like the curtain).
3. PULL UP THE COLLECTOR (IT IS PRESSURE MOUNTED)
4. Remove the nozzles and the manifold covers, clean them.
5. Remove and clean the main suction filter of the pump. (IT IS PRESSURE MOUNTED)
6. Fit filter, injectors, and collector.

ATTENTION: IT IS VERY IMPORTANT, WHEN REPLACING THE MANIFOLD THAT THE INJECTORS ARE COMPLETELY PERPENDICULAR TO THE SAME. IF THE CUBES AT THE END ARE TWISTED, THEY CAN REMAIN WITHOUT WATER.

7.4 CLEANING THE ICE BIN AND EXTERIOR

1. Disconnect the machine, close water faucet and empty storage bin of ice.
2. Use the cleaner/water solution to clean all surfaces of the bin. Use a nylon brush or cloth. Then rinse all areas thoroughly with clean water.
3. Use the sanitizer/water solution to sanitize all surfaces of the bin. Use a nylon brush or cloth.
4. Rinse with plenty of water, dry, run the machine and open water faucet.

7.5 WATER LEAKAGE CHECKING

This must be done whenever maintenance is carried out on the machine: check all water connections, braces, tubes and hoses in order to eliminate leaks and prevent breakages and flooding.

7.6 CLEANING THE HYDRAULIC SYSTEM

1. Set the switch to the OFF position after ice falls from the evaporator at the end of a harvest cycle or set the switch to the OFF position and allow the ice to melt off the evaporator.

CAUTION: Never use anything to force ice from the evaporator.

2. Remove all ice from the bin.
3. Remove the back panel and the top panel. Remove the auxiliary pipe for drain operations near the pump and empty the water tray. Return it to their original position to avoid water spill.

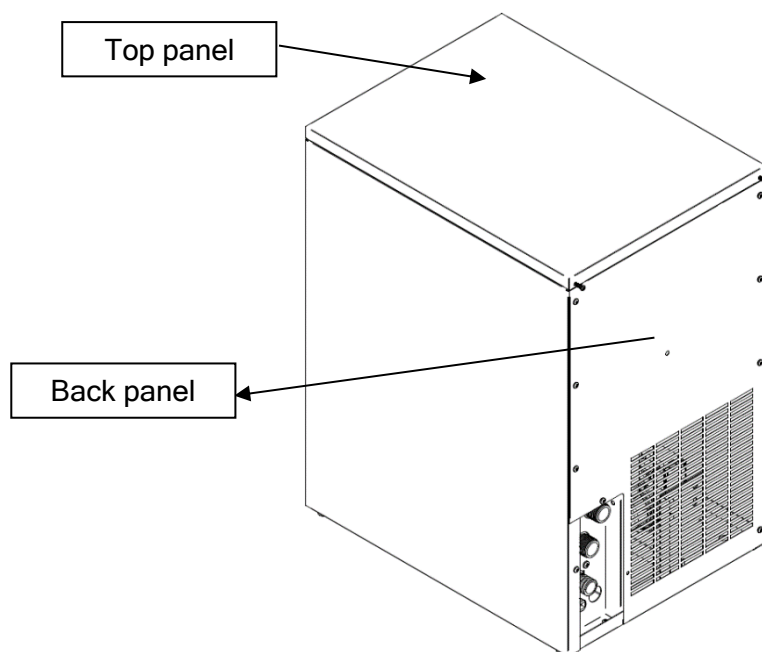

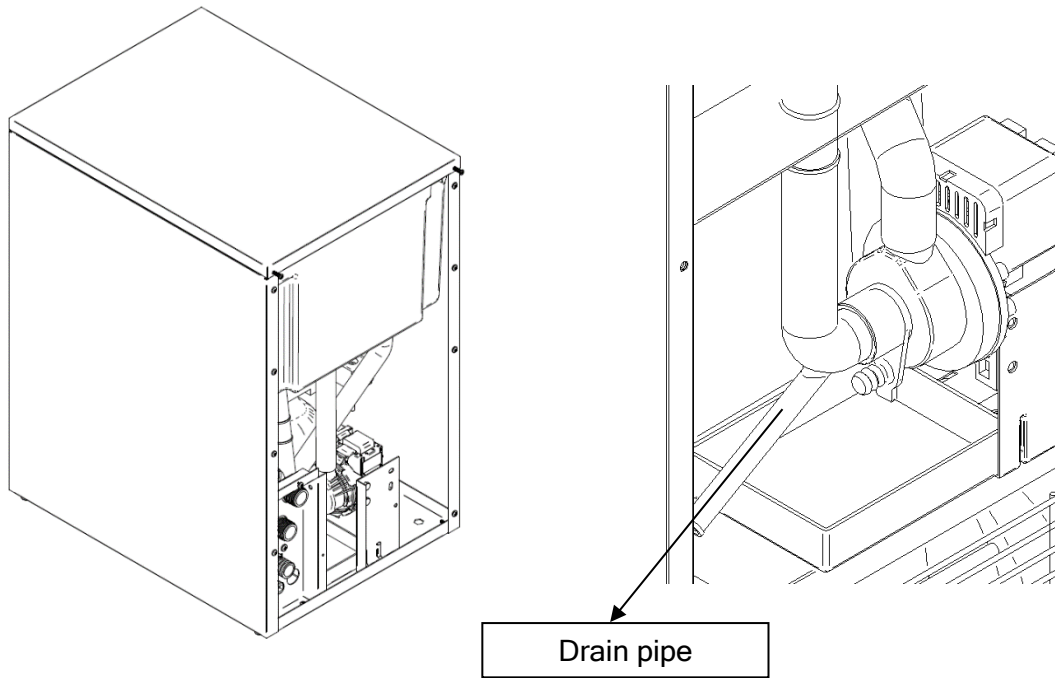

4. Remove the water overflow and empty the water tray. Return it to their original position to avoid water spill.

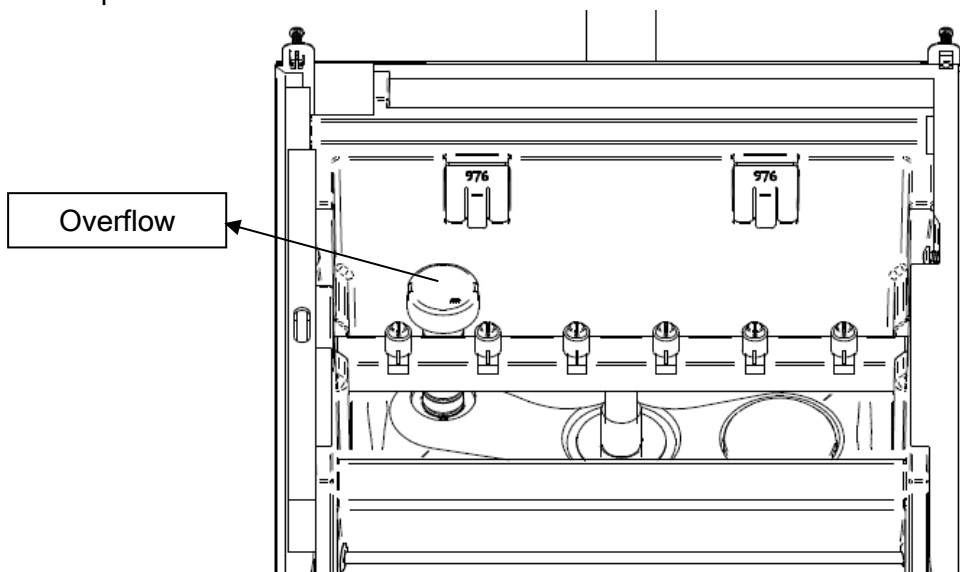

5. Prepare a solution of an appropriate product for the cleaning of ice machines (lime). Do not use hydrochloric acid. We recommend the use of any approved scale removal product prepared according to the manufacturer's instructions as for example CalKlin.
6. Fill water tray with the solution.

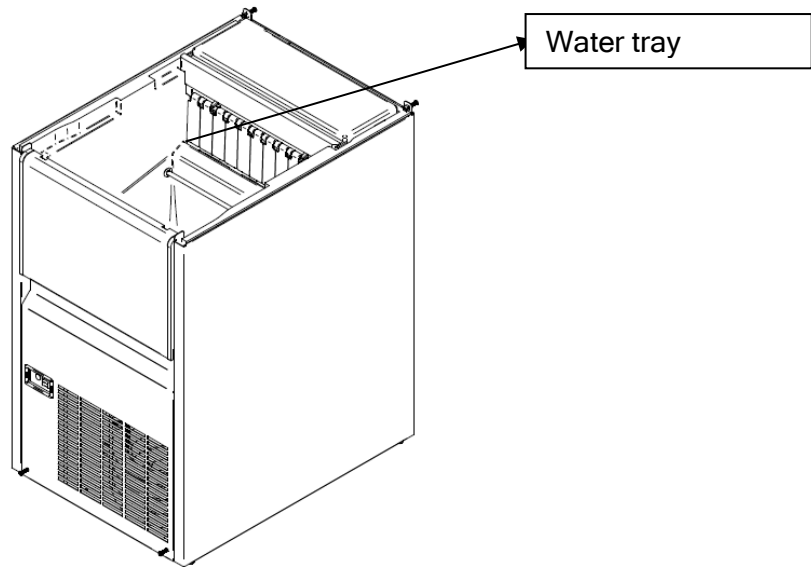

7. Disconnect power. Turn on the machine pushing SW3 (see picture). Let solution stand for 30-40 minutes and then switch off the machine. Disconnect power.

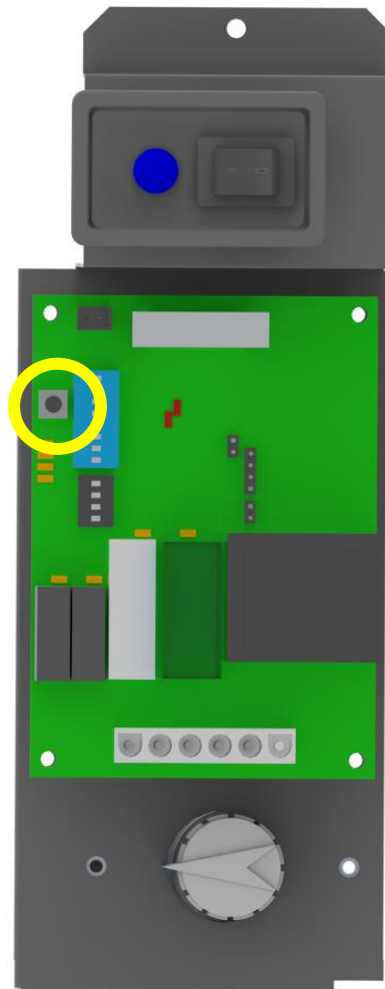

8. Remove the drain pipe to drain and purge out the ice machine scale remover and residue.
Replace it.
9. Mix enough cleaning solution to clean parts and interior food zone surfaces.
10. Clean all surfaces of the shield with the cleaner solution using a brush (not a wire brush) or cloth.
Rinse all areas with water.
11. Clean all the interior surfaces of the freezing compartment (including storage bin) with the cleaner solution using a brush or cloth. Rinse all areas with water.
12. Mix a disinfectant solution using a sanitizer approved for food equipment (following the manufacturer's instructions for use).
13. Sanitize all the interior surfaces of the freezing compartment (including the storage bin) applying liberally sanitizer solution, using a cloth or sponge.
14. Connect power and water supplies.
15. Fill water reservoir with the sanitizer solution.
16. Switch on machine in order to run water pump. Let solution stand for 20 minutes and switch off.
17. Remove the auxiliary cap to drain and purge out the sanitizer solution and residue. Replace it.
18. Fill the water reservoir with water and switch on the machine to allow water to circulate for 5 minutes and then stop the machine. Repeat this operation two more times to rinse thoroughly (by removing the cap to drain the water and replacing it for each cleaning cycle).
19. Return the back metal lid and the top panel to their position.
20. Switch on machine and discard the first two harvests.

7.7 MAINTENANCE TABLE

ACTION	MONTHLY	QUARTERLY	SEMESTERLY	ANNUAL	BIENNIAL	T UNIT
Cleaning air condenser						30 minutes
Cleaning water condenser						90 minutes
Inyectors cleaning						45 minutes
Exterior and stock bin cleaning						30 minutes
Cleaning hydraulic system						30 minutes
General cleaning						--

	Depending on the characteristics of the environment
	Indispensable/Essential
	Depending on water quality
	Performed by owner

Maintenance and cleaning procedures, as well as problems resulting from their non-performance, **ARE NOT COVERED BY THE GUARANTEE.** Service personnel will bill you for travel expenses, time spent and materials required for maintenance and cleaning of the unit.

8. TROUBLESHOOTING GUIDE

8.1 GENERAL QUESTIONS

PROBLEMS	POSSIBLE CAUSES	SOLUTION
None of the electrical systems work.	No power	Check power supply and connection
	Switch Interruptor OFF	Power on
None of the electrical systems work. Front pilot is ON	Full bin status (LE4 on) with no ice. Thermostat defective or incorrectly set	Check. Replace
	PCB alarm.	Check the LED code
PCB ALARMS See section 6		
Safety pressure switch	Dirty condenser	Clean condenser
	Machine wrong located	Change machine location
	Defective fan	Check. Replace
	Water machine: Faulty water valve	Check. Replace
	Defective safety / cooling switch	Check. Replace
NTC probe error	Defective probe	Check. Replace
	Defective probe plug connection	Check.
Ice cycle timeout	No frozen evaporator	Check refrigeration system
	NTC probe faulty contact	Check probe fitting
	Faulty hot gas valve/coil	Check. Replace
Harvest cycle timeout	Harvest do not happen	Check water inlet strainer
	Faulty hot gas valve/coil	Check. Replace
Wrong cycle sequence	DIP-Switch 2-4 OFF	Set ON
OTHER PROBLEMS		
Compressor does not run, but voltage is supplied	Compressor/electrical equipment defective	Check/replace
Compressor runs, but does not cool	Refrigeration system not working properly	Check load and components
Plate is energized, but does not turn on	Internal board fuse open	Replace
Shutdown due to full store, but no ice	Failure of the stock thermostat	Replace
	Thermostat NOK placement	Correct positioning
Abnormal noise in the machine	Fan or fan blades in bad condition or loose	Fix or substitute
	Vibrating pipes or components	Reposition and/or fix
	Noise in compressor	Substitute
White and partially formed cubes.	Dirty nozzles	Clean/Replace
	Dirty suction filter	Clean/Replace
	Lack of water at cycle's end	Check water leaks
Too large cubes	Freezing time too large	Adjust by dip-switches 1-4
	Probe makes bad contact	Adjust by means of dip switches
Too small cubes	Freezing time too short	Adjust by dip-switches 1-4
	Dirty condenser	Clean
	Faulty probe	Replace
Not all cubes are released	Harvest time too short	Adjust by dip-switches
	Freezing time too large (Ice slab)	Adjust by dip-switches
	Dirty evaporator	Clean
	Faulty hot gas valve	Check / replace
	Lack of water input	Check net pressure and input filters
Low ice production	Blocked condenser or air access to condenser	Clean condenser; improve air circulation
	Faulty hot gas valve, doesn't close totally.	Replace
	Low performance refrigeration system	Check

9. TECHNICAL DATA

For more technical information scan the following QR code or click the link:



- Specification sheets
- User manual
- Exploded views
- CAD / REVIT drawings
- Technical videos

<https://acortar.link/7SkuZY>