

NDP 20

ITV
ICE makers



DESPIECE / REPUESTOS
EXPLODED VIEW / SPARE PARTS
EXPLOSIONSZEICHNUNG / ERSATZTEILE
VUE ÉCLATÉE / PIÈCES DÉTACHÉES
ESPLOSO / RICAMBI

ITV | ICE makers **SERVICE** 

CABINET



NDP20

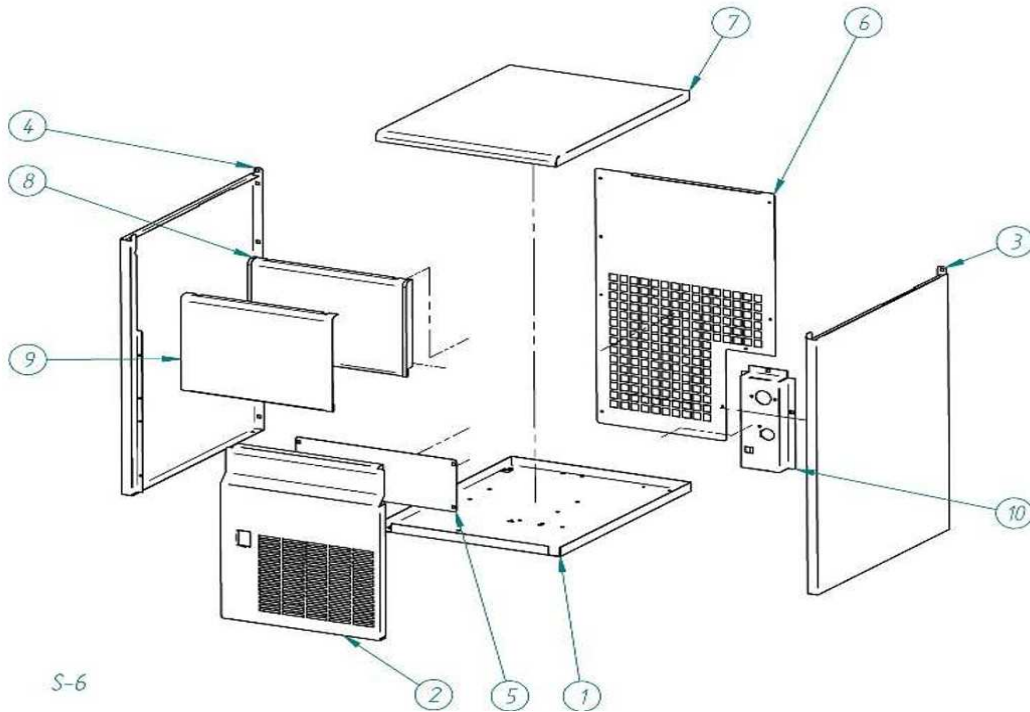

NAME		
1	BASEMENT	1300
2	FRONT PANEL	1933
3	RIGHT PANEL	2294
4	LEFT PANEL	2295
5	FRONT REINFORCEMENT	1327
6	REAR PANEL	1794
7	TOP COVER	1925
8	DOOR	853
9	DOOR COVER	1017
10	JUNCTION REINFORCEMENT	1934

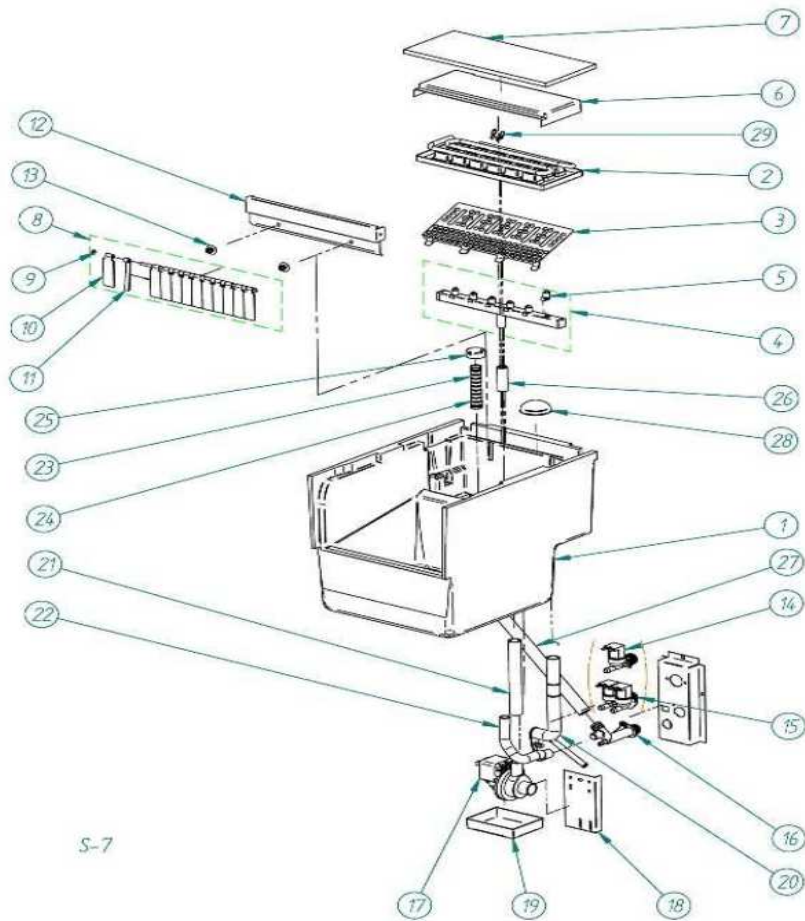

	NAME	
1	SOTCK BIN	7002
2	EVAPORATOR	6921
3	ICE CUBES RAMP	31114
4	COLLECTOR	7333
5	SPRAY NOZZLE	526
6	EVAPORATOR COVER	1432
7	EVAPORATOR INSULATION	-
8	COMPLETED CURTAIN	5223
9	CURTAIN JOINT	107
10	OUTSIDE CURTAIN	1213
11	INSIDE CURTAIN	1212
12	EVAPORATOR SUPPORT	1435
13	CURTAIN CLIP	3533
14	ELECTROVALVE 1B	6982
	ELECTROVALVE 1B 115V/60HZ	5400
15	ELCTROVALVE 1B/1B	7693
	ELECTROVALVE 1B/1B 115V/60H.	4900
16	COLECTOR DESAGÜE	363
	PUMP 220V/50HZ	4769
17	PUMP 220V/60HZ	32048
	PUMP 115V/60HZ	32049
18	PUMP SUPPORT	4613
19	PUMP TRAY	4521
20	SUCTION PIPE	4961
21	FORCE PIPE	4744
22	DRAIN PIPE	2189
23	OVERFLOW PIPE	4426
24	SEAL JOINT	4496
25	OVERFLOW CAP	4427
26	COLLECTOR PIPE	993
27	DRAIN TUBE	2752
28	FILTER	580
29	TUBE CLIP	4534

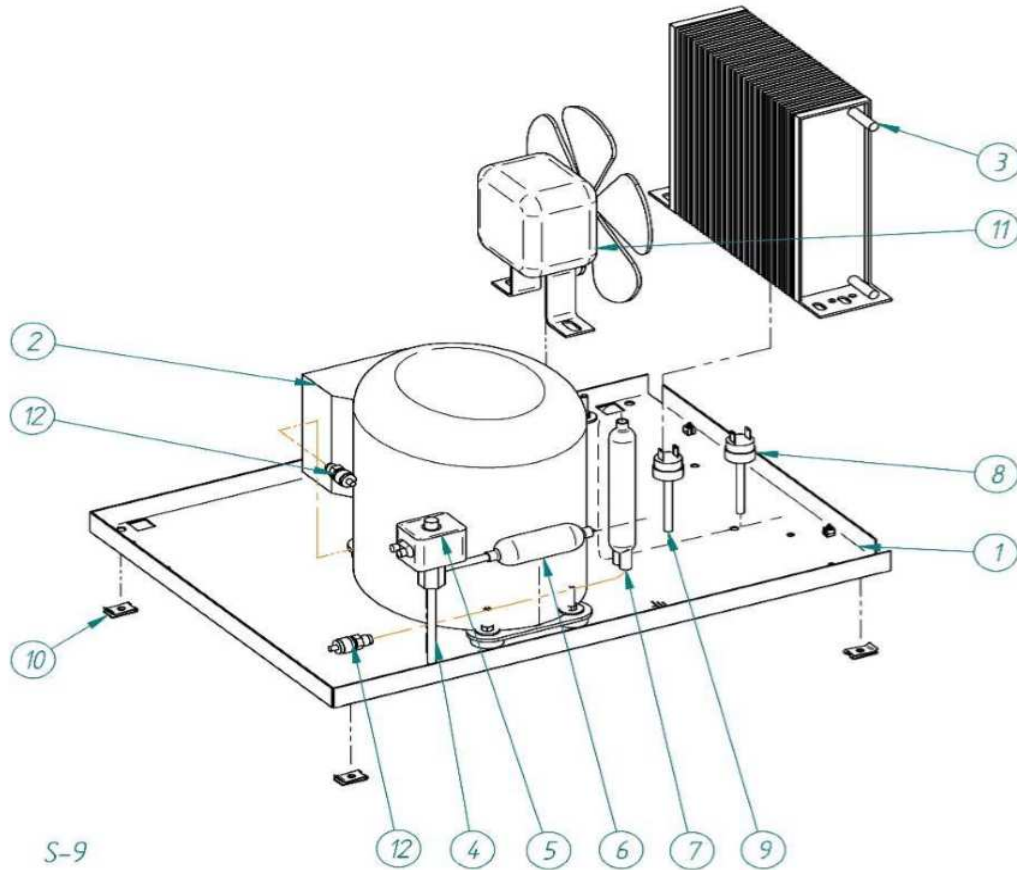

S-9

NAME		
1	BASEMENT	1300
2	COMPRESSOR	220V/50H 8435 115/60Hz 2800
3	CONDENSER	6907 UNTIL S/N 1291829 2423
4	HOT GAS VALVE	6904
5	COIL 220V/50HZ	6906
	COIL 115V/60HZ	5414
6	FILTER	-
7	DRIER	6856
8	CONDENSATION PRESSURE SWITCH	7476E
9	HIGH PRESSURE SWITCH	334
10	CLAMP	5284
11	CONDENSER FAN	220V/50HZ 2170+587
	CONDENSER FAN	115V/60HZ 2913
12	REFRIGERATION LOAD VALVE	335

WATER CONDENSER UNIT

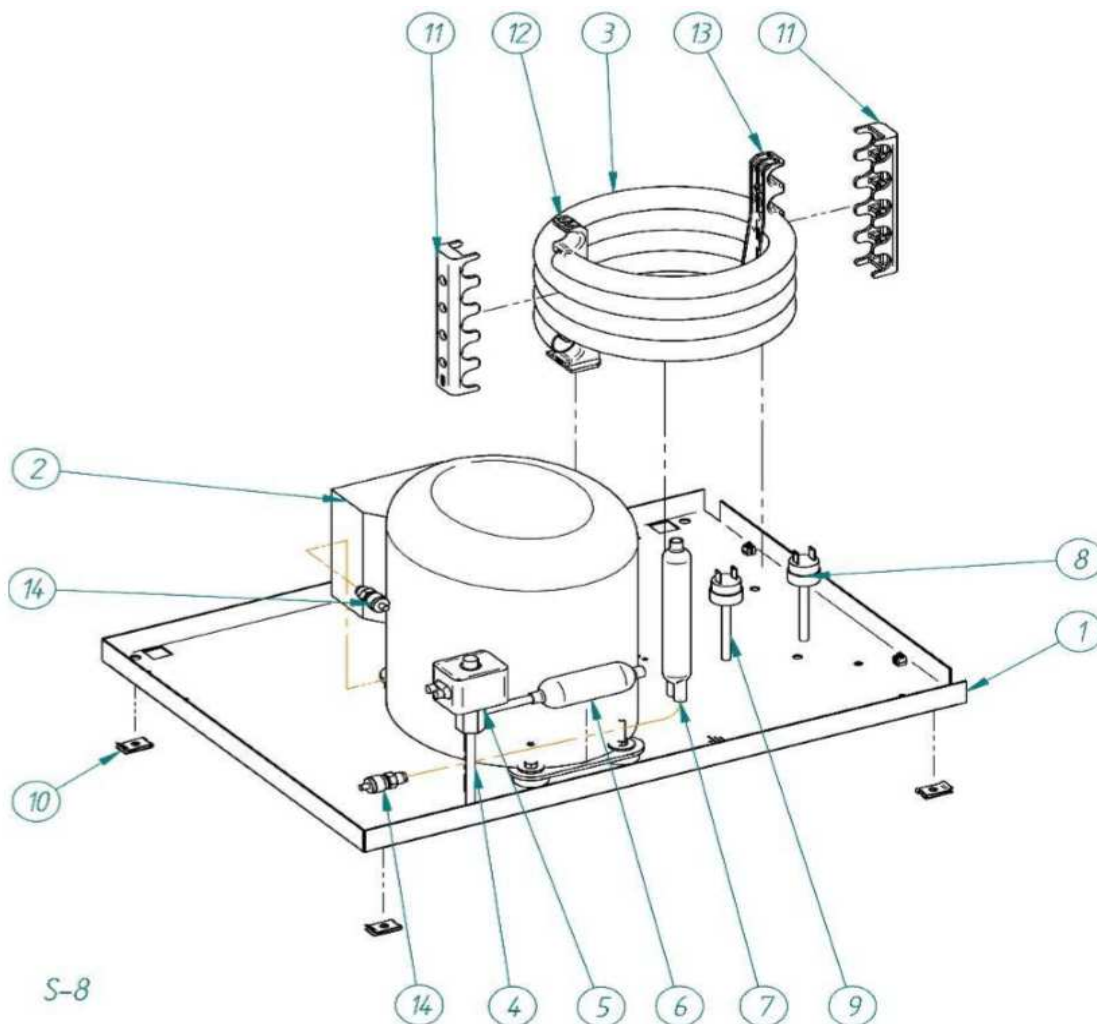

NAME		
1	BASEMENT	1300
2	COMPRESSOR	220V/50H 8435 115/60H 2800
3	WATER CONDENSER	5224
4	HOT GAS VALVE	1473
	UNTIL S/N 1291829	6904
5	COIL 220V/50HZ	6906
	UNTIL S/N 1291829	5173
	COIL 115V/60HZ	5414
6	FILTER	448
7	DRIER	6856
8	CONDENSATION PRESSURE SWITCH	7476E
9	HIGH SWITCH PRESSURE	4528
	UNTIL S/N 1291829	334
10	CALMP	309
11	OUTSIDE BRACKET	4038
12	HIGH BRACKET	4037
13	LOW BRACKER	4036
14	REFRIGERATION LOAD VALVE	335

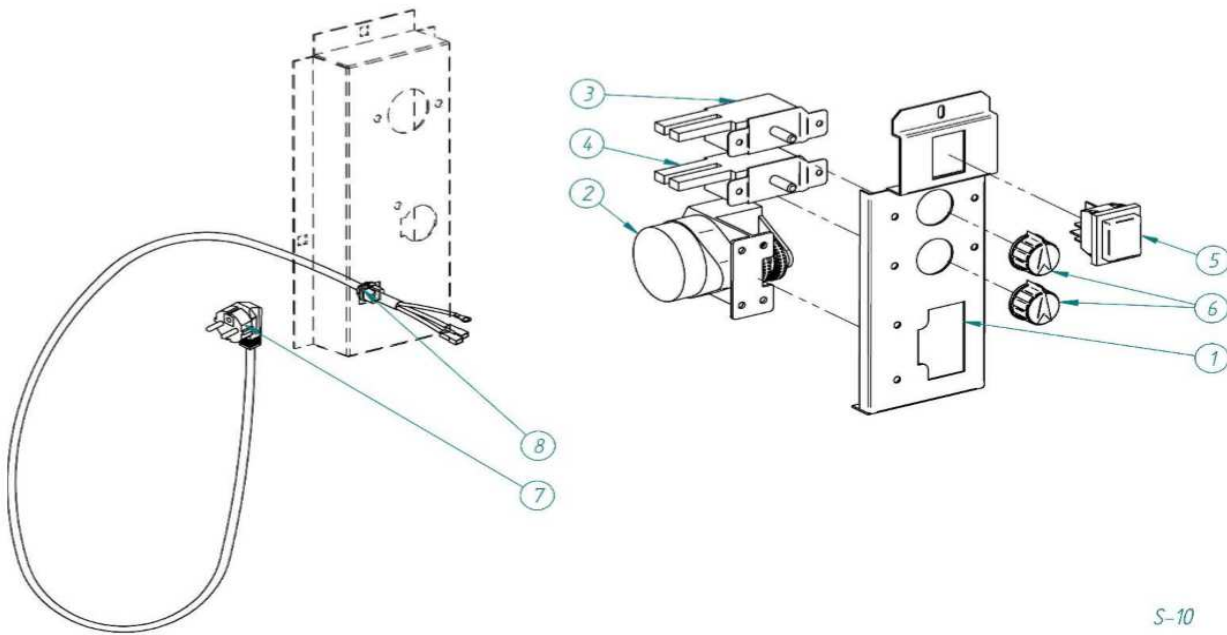

S-10

	NAME	
1	ELECTRIC BOARD	1988
2	15' TIMER	220V/50HZ 4864C
	15' TIMER	115V/60HZ 4865C
CYCLE THERMOSTAT		
3		153
		UNTIL S/N 1291829 4513
4	STOCK THERMOSTAT	274
5	SWITCH	2287
6	THERMOSTAT BUTTON	272
7	ATTACHMENT PLUG 220V/50HZ	408
	ATTACHMENT PLUG 115V/60HZ	2771
8	CABLE LOCKER	664
	CABLE LOCKER 115V/60HZ	4907

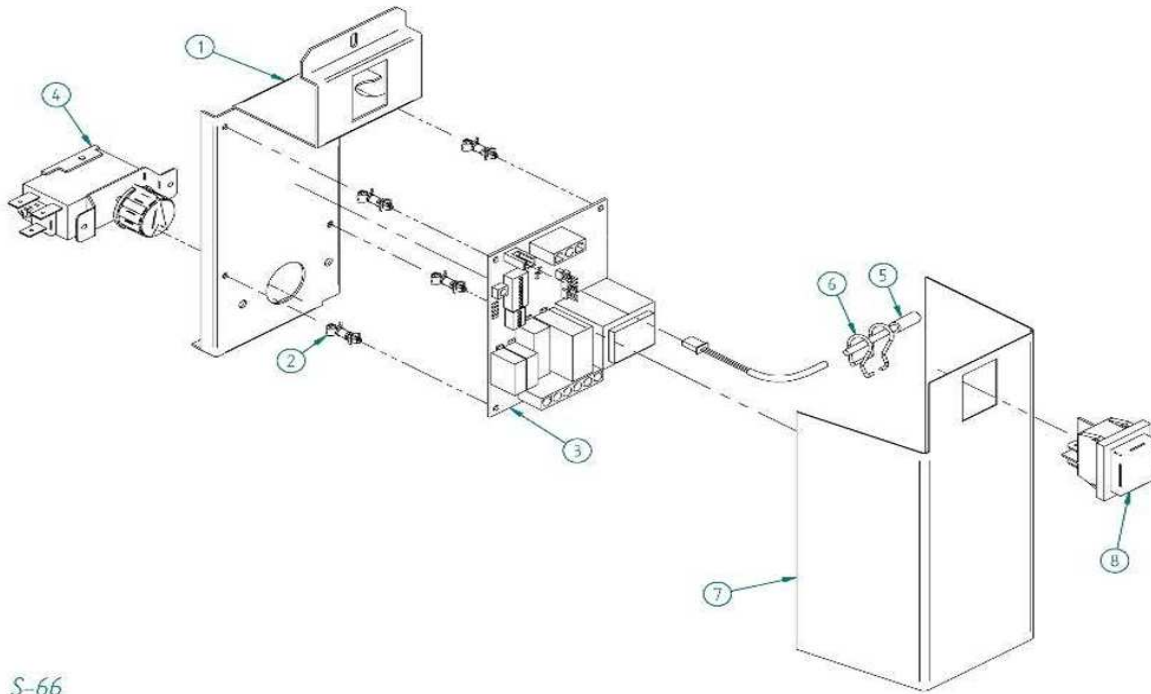

	NAME	
1	ELECTRIC BASE	8166
2	ELECTRONIC BOARD CLAMP	8186
3	ELECTRONIC BOARD	8143
4	STOCK THERMOSTAT	274
5	TEMPERATURE PROBE NTC	3004
6	TEMPERATURE PROBE CLAMP	8218
7	ELECTRONIC BOARD CURTAIN	8213
8	SWITCH	2287

S-66