

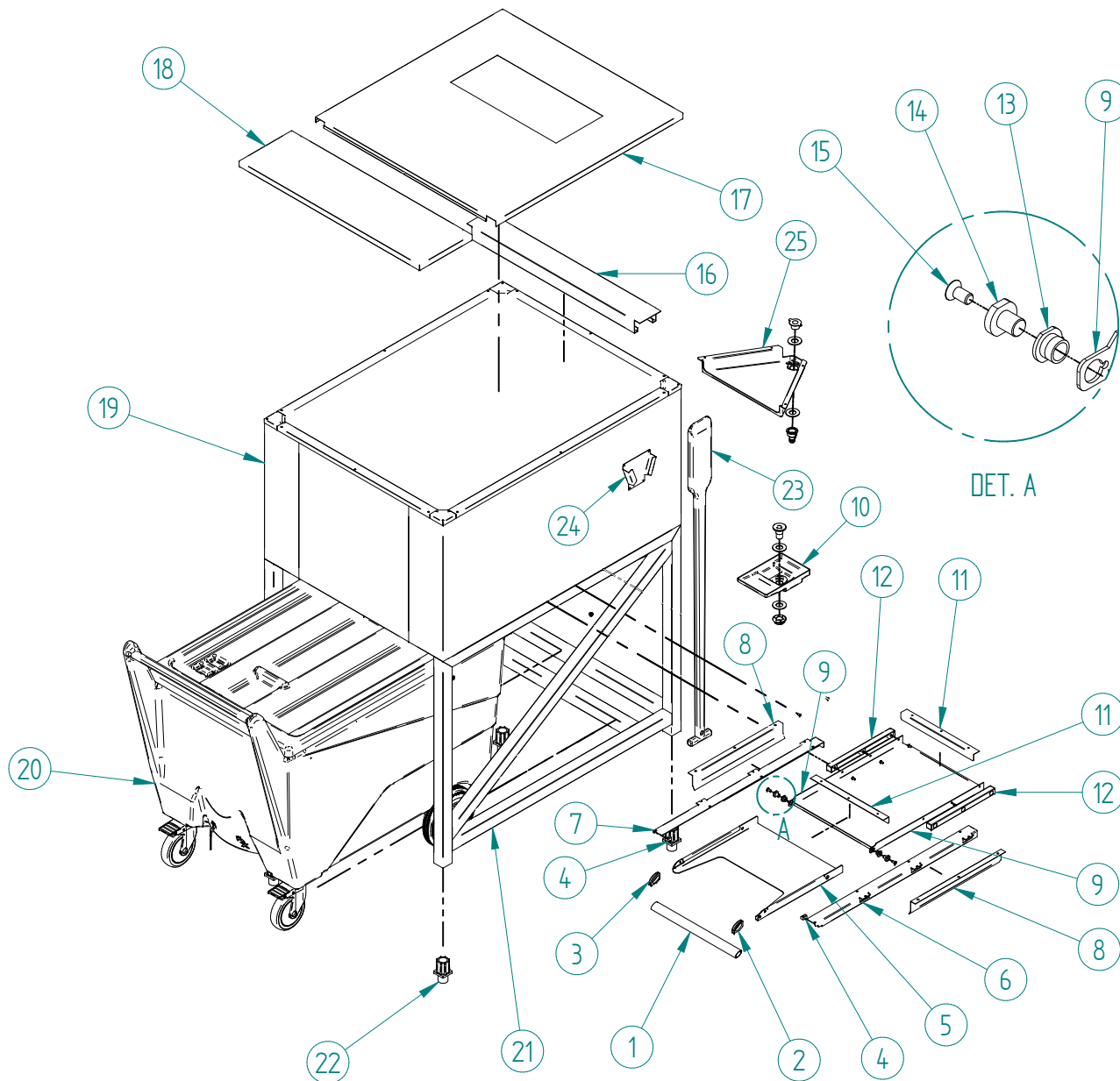

**ITV**  
ICE makers



DESPIECE / REPUESTOS  
EXPLODED VIEW / SPARE PARTS  
EXPLOSIONSZEICHNUNG / ERSATZTEILE  
VUE ÉCLATÉE / PIÈCES DÉTACHÉES  
ESPLOSO / RICAMBI



ITEM	DESCRIPTION	SCS 150
1	OVAL PULL HANDLE	8853
2	RIGHT PULLER HANDLE	30134
3	LEFT PULLER HANDLE	30135
4	TRAIL STOP	8858
5	ICE PULL HANDLE	8874
6	LEFT GUILLOTINE GUIDE BRACKET	8854
7	RIGHT GUILLOTINE GUIDE BRACKET	8857
8	DEFLECTOR BRACKET	8766
9	ICE EXTIT CLOSING TRAY	8764
10	LOWER DRAIN TRAY SET	33415
11	ICE EXIT SPAT	8765
12	GUILLOTINE GUIDE BRACKET	8852
13	DOOR BUSHING	1001
14	BIN HINGE AXLE	6735
15	SCREW DIN 965 M-6X12 INOX	6753
16	BIN COVER REINFORCEMENT	31195
17	FIXED COVER SIDE	IQ 31320 MS - MDP 31433 MS22 31189
18	UNFIXED COVER SIDE	IQ 31190 MS - MDP 31190 MS22 31190
19	BODY BIN	31153
20	CART	30660
21	BIN METALLIC STRUCTURE	31163
22	ADJUSTABLE LEG INOX 40X40	30138
23	BIN SHOVEL	30148
24	SHOVEL SUPPORT KIT	31213
25	UPPER DRAIN TRAY SET	33414

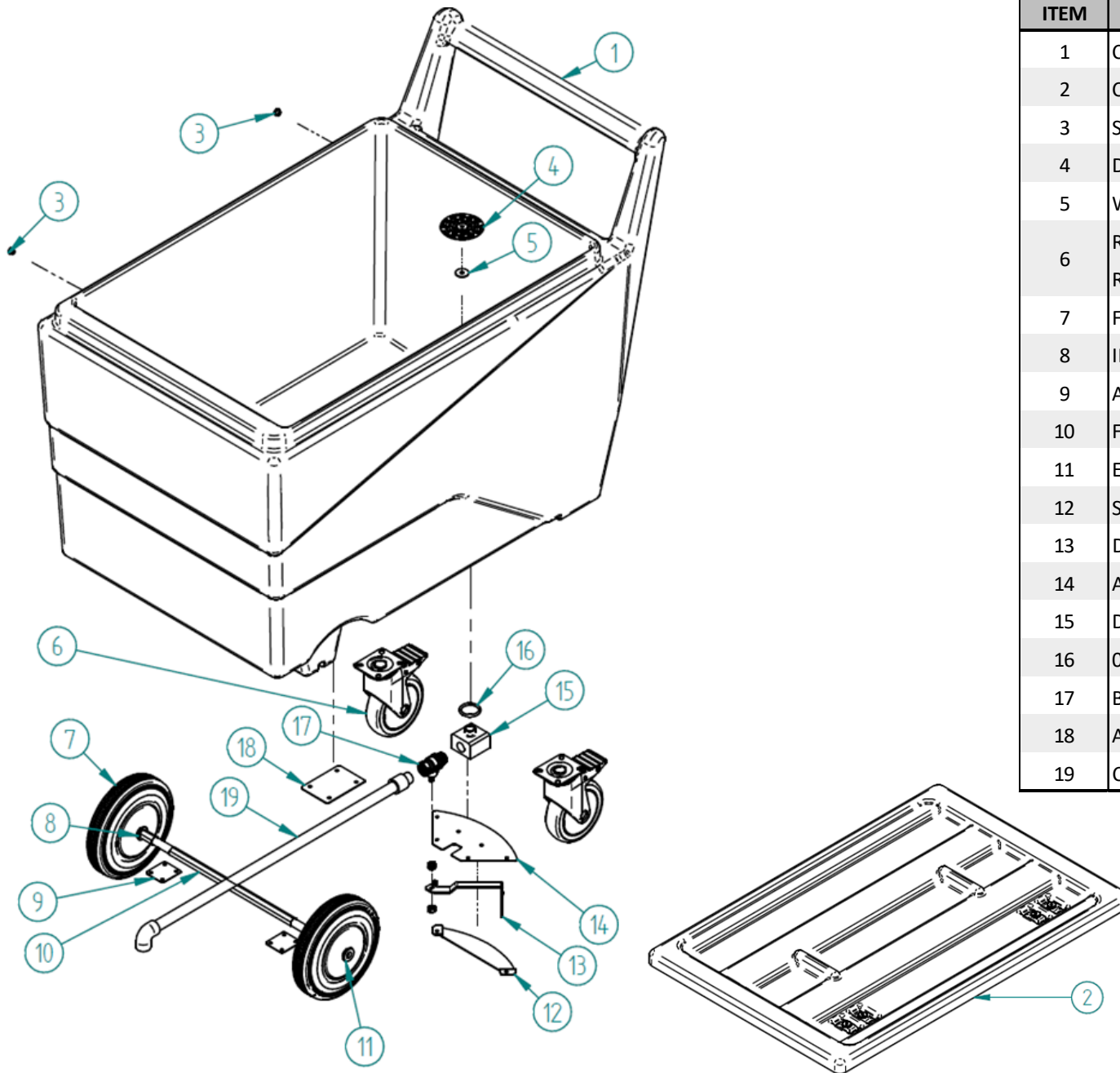

ITEM	DESCRIPCION	CODE
1	CART	8926
2	CART COVER	31217
3	SCREW FOR THE COVER	8843
4	DRAIN GRILL	8838
5	WATER DEFECTOR	1582
6	REAR WHEEL REAR WHEEL before s/n 18267761	8862A 8862
7	FRONT WHEEL 200 MM DIAM	8861
8	INT. WASHER FRONT WHEEL	8836
9	ANCHOR SHEET FRONT WHEEL	8736
10	FRONT WHEL SHAFT	8863
11	EXT. WASHER FRONT WHEEL	8837
12	SUPPORT BRIDGE	8842
13	DRAIN VALVE FAUCET	8839
14	ANCHOR SHEE VALVE	8841
15	DRAIN CONNECTION	8840
16	O-RING 32X4	8869
17	BALL VALVE 1/2" M-H	8868
18	ANCHOR SHEET DRAIN TUBE	8737
19	CART DRAIN TUBE	31216