

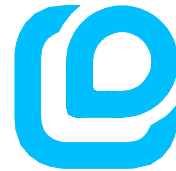

**ITV**  
**ICE**makers

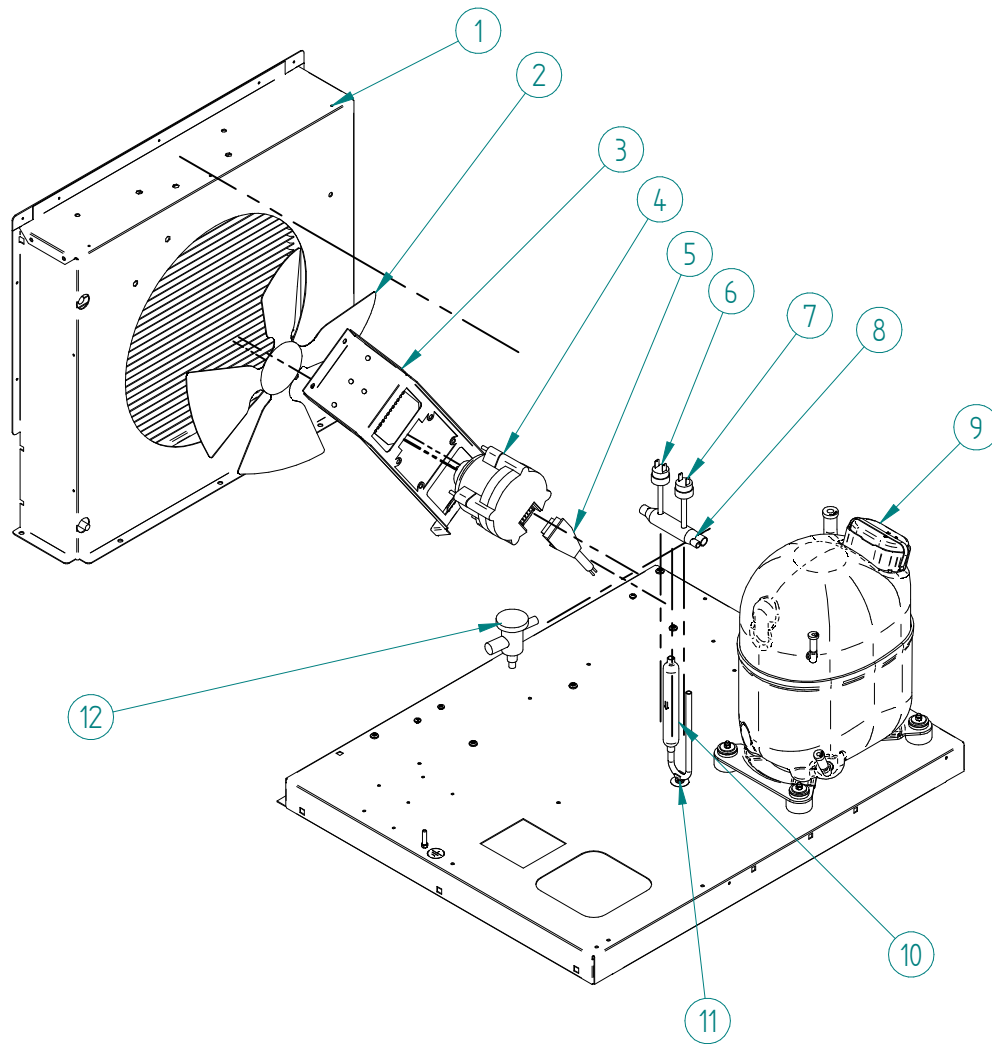

DESPIECE / REPUESTOS  
EXPLODED VIEW / SPARE PARTS  
EXPLOSIONSZEICHNUNG / ERSATZTEILE  
VUE ÉCLATÉÉ / PIÈCES DÉTACHÉES  
ESPLOSO / RICAMBI



ITEM	DESCRIPTION	150/160	200	400	600
1	AIR CONDENSER	486A	487A	33597	
2	FAN BLADE	4887		6398	
3	FAN SUPPORT	N/A		32653	
4	FAN MOTOR	220V/50HZ	28	32654	
5	FAN MOTOR WIRE	220V/50HZ	N/A	32656	
6	FAN CONTROL PRESSURE SWITCH	31160E			
7	HIGH PRESSURE SWITCH	31660E			
8	PRESSURE SWITCH COLLECTOR	31444		32695	
9	COMPRESSOR	220V/50HZ	33303   33305	31310	33348
		380V/50HZ	N/A		32817
10	FILTER DRIER	7896			
11	PLASTIC CLIP 1/4"	3533			
12	EXPANSION VALVE	N/A		31524	32346

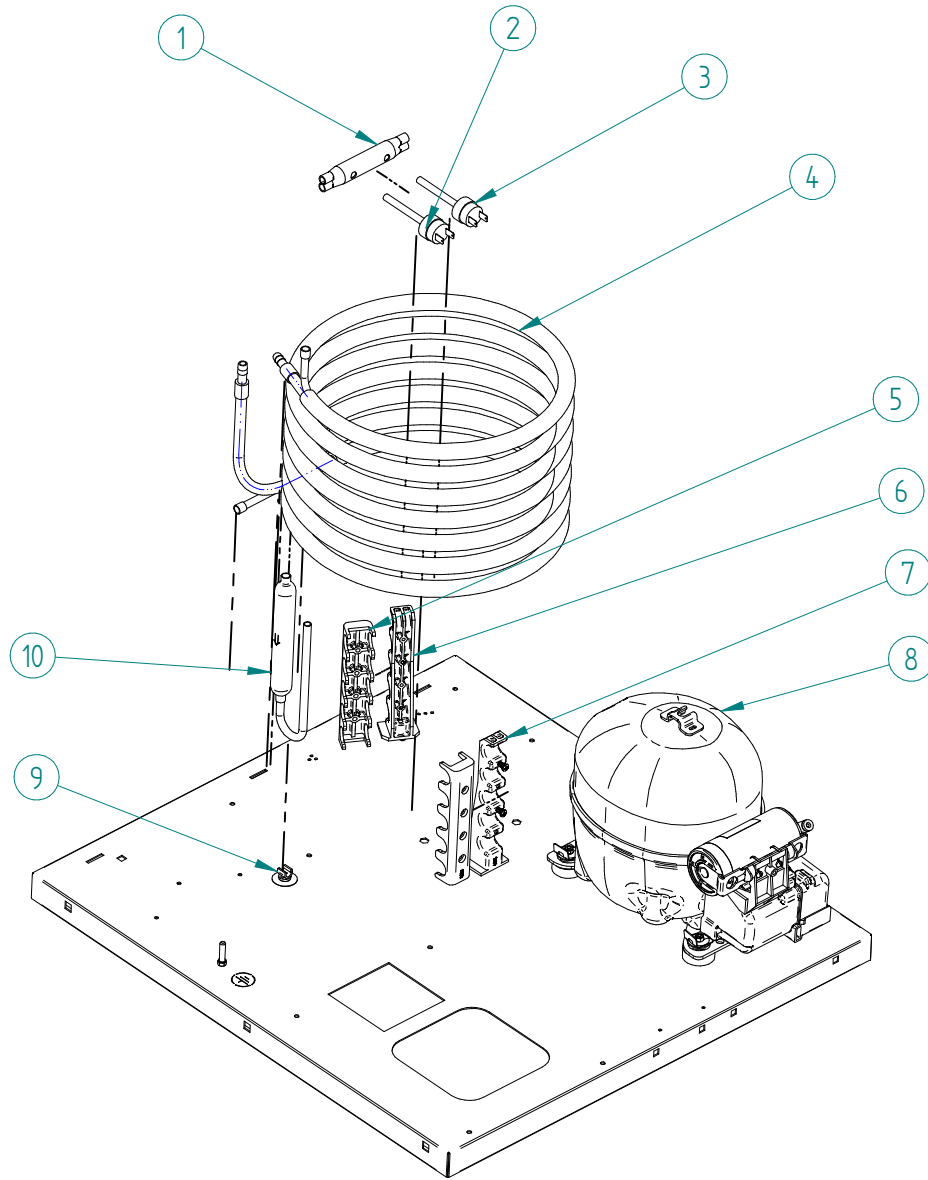

ITEM	DESCRIPTION	150/160	200	400	600
1	PRESSURE SWITCH COLLECTOR	31444		32695	
2	FAN CONTROL PRESSURE SWITCH		31160E		
3	HIGH PRESSURE SWITCH		31660E		
4	WATER CONDENSER	5243	5244	33671	
5	WATER CONDENSER EXTERNAL SUPPORT	4038		N/A	
6	WATER CONDENSER LOWER SUPPORT	4037		N/A	
7	WATER CONDENSER UPPER SUPPORT	4036		N/A	
8	COMPRESSOR 220V/50HZ	33303	33305	31310	33348
9	PLASTIC CLIP 1/4"		3533		
10	FILTER DRIER		7896		

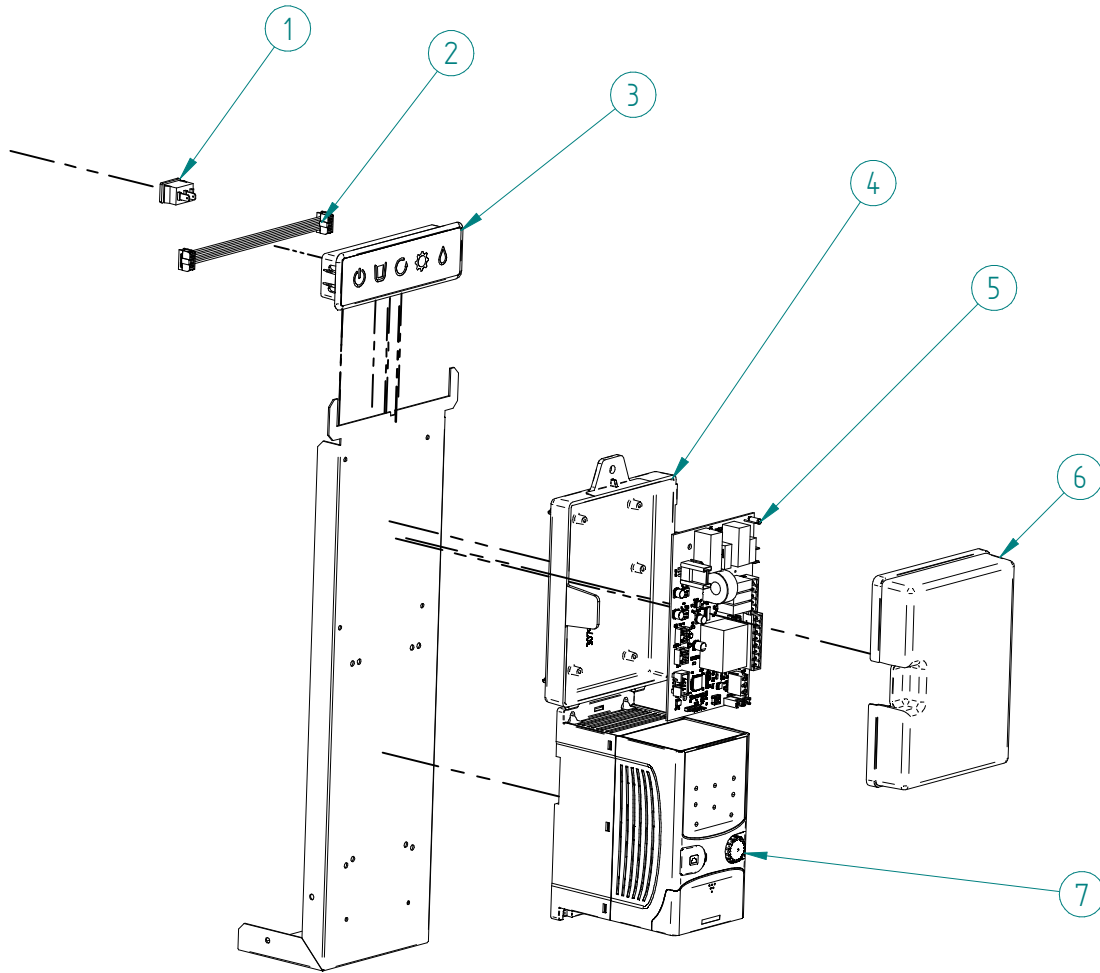

ITEM	DESCRIPTION	150/200	400	600 (I)	600 (III)
1	ATEX ON/OFF SWICH		32416		
2	DISPLAY CABLE	34457	34162		34457
3	PILOT PANEL		30566B		
4	ELECTRIC BOX BASE		30792		N/A
5	ELECTRONIC BOARD		33799		33800
6	LID ELECTRICAL BOX		31274		34550
7	FREQUENCY INVERTER (I)	N/A	34286		N/A

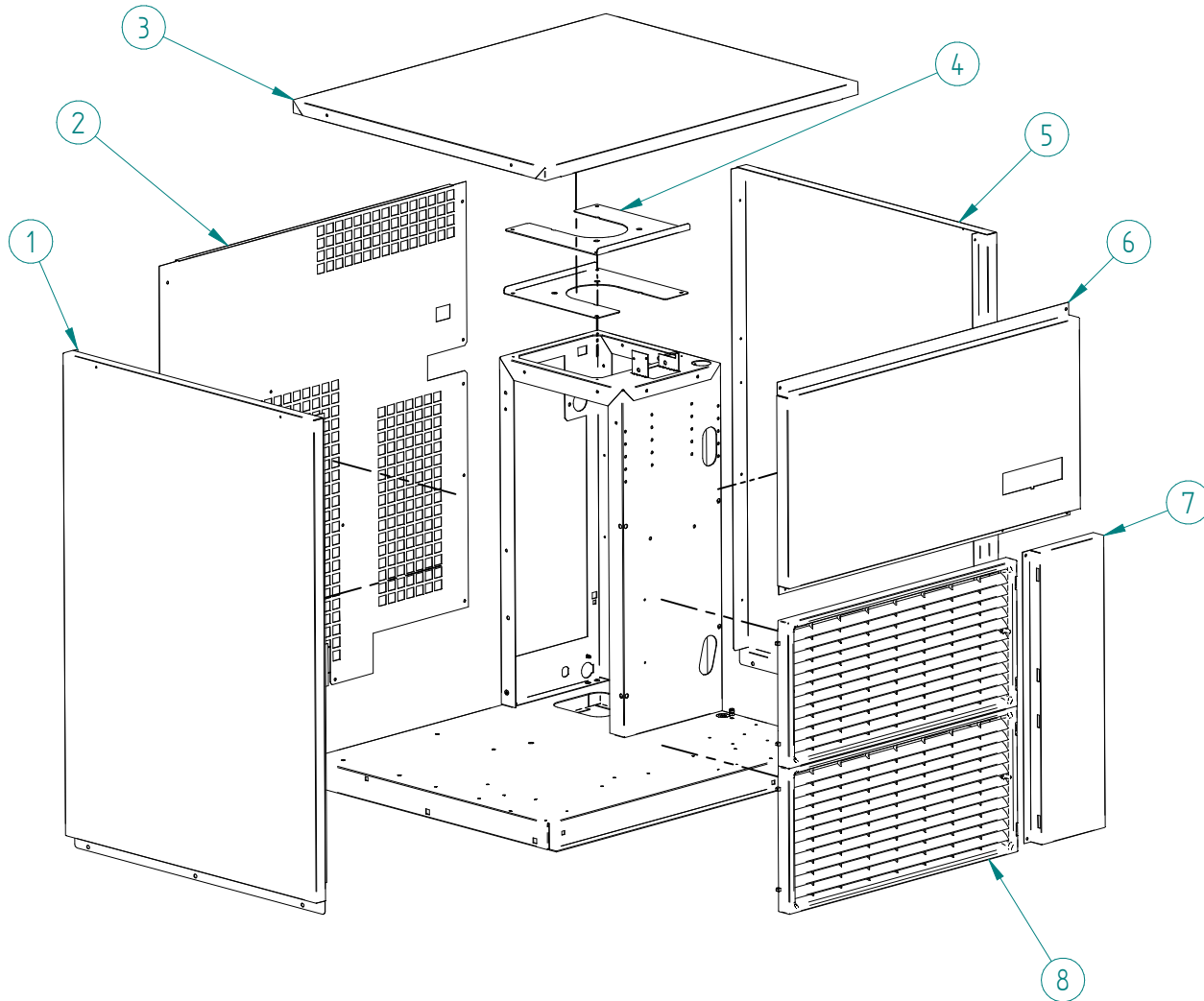

ITEM	DESCRIPTION	150/160/ 200	400	600
1	LEFT SIDE PANEL	34489	34535	34533
2	REAR COVER	34104	34107	34110
3	TOP PANEL	2465U	8784	
4	FLANGE SUPPORT	2455	2477	
5	RIGHT SIDE PANEL	1927U	34534	34532
6	FRONT PANEL (I) (III)	34068	34069	34070
		N/A	34069	34070
7	FRONT VERTICAL PANEL	N/A	6657	
8	FRONT LOUVER	6084	4186	

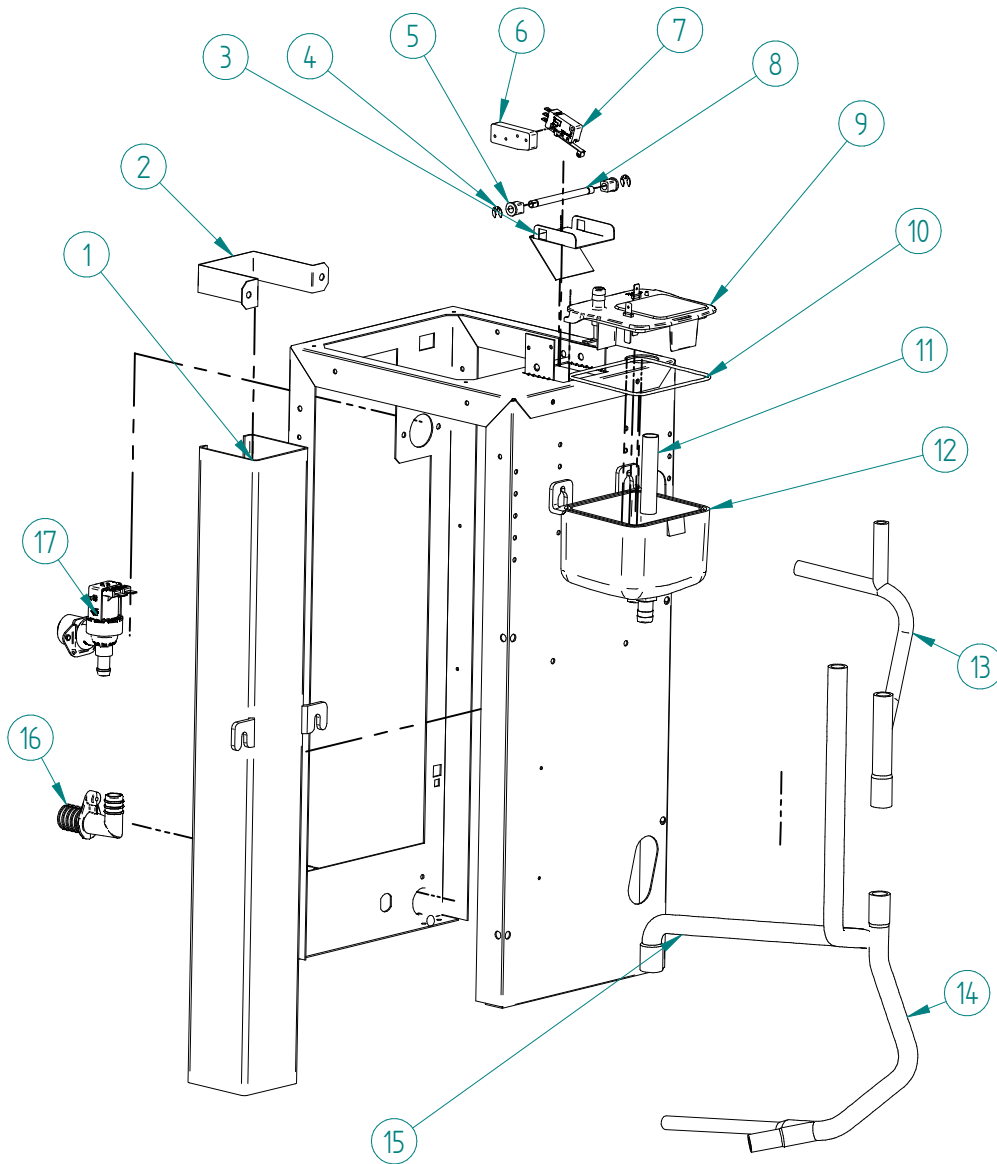

ITEM	DESCRIPTION	150/160/ 200	400	600
1	OUTLET ICE TUBE	2441	2443	2444
2	OUTLET ICE TUBE SUPPORT		2447	
3	STOP BASCULE FLAP		33831	
4	SAFETY RING		6004	
5	BUSHING		171	
6	SUPPLEMENT STOP BASCULE FLAP		2514	
7	MICRO SWITCH (ATEX)		32998	
8	BASCULE AXIS		33775	
9	WATER BIN COVER		34123	
10	O-RING		34150	
11	OVERFLOW TUBE		2505	
12	WATER BIN		34122	
13	INTEL TUBE W	N/A	N/A	34569
14	EVAPORATOR WATER INLET TUBE	34094	34097	
15	DRAIN TUBE	34093	34096	
16	DRAIN CONNECTION		30850	
17	WATER INLET VALVE		34126	

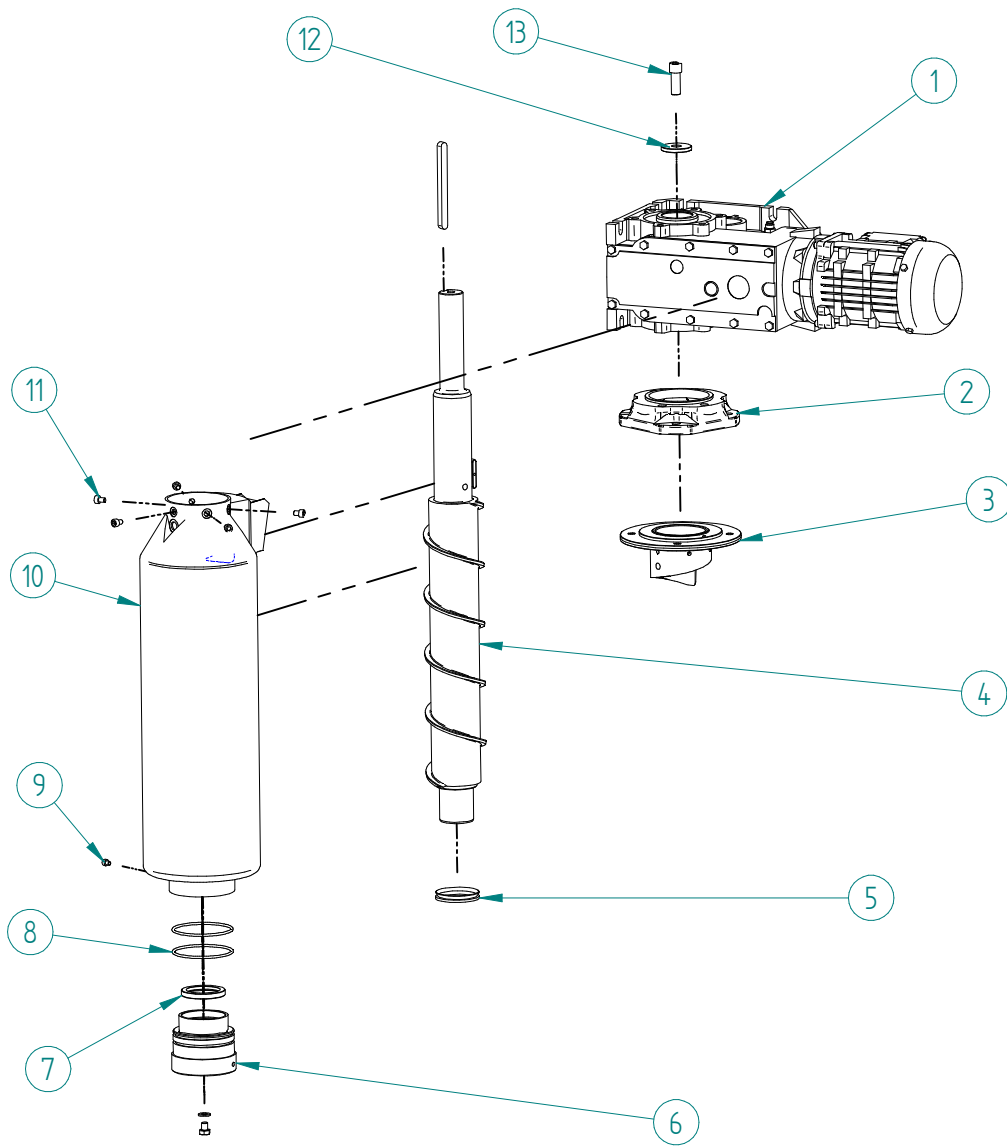

ITEM	DESCRIPTION	150/160/ 200	400	600
1	GEAR MOTOR* 220V/50HZ 380V/50-60HZ	33707	N/A	30363A 30363A
2	FLANGE GEAR MOTOR*	N/A	30874B	
3	FLANGE/PLATE	5365	5366	
4	AUGER*	2245	33931	894
5	V-RING	2334	2335	
6	LOWER BEARING	125A	162A	
7	SEAL	725	726	
8	O-RING BEARING	2256	2484	
9	BEARING SCREW	2595		
10	EVAPORATOR	7633A	7635	7636A
11	FLANGE SCREW	2871 (M6) -- 3560 (M10)		
12	AUGER TOP SPACER*	2512	33930	1850
13	AUGER TOP SCREW*	3297	719	
14	EVAPORATOR ASSEMBLY (From 4 to 12)	7194	7179	7177