

MR 400 TROUBLESHOOTING GUIDE

The MR 400 is a machine with electronic board and display, indicating in the same faults by means of alarms. This document indicates the alarms and how to solve the problems that affect the operation of the unit.

Many of the alarms indicated by the display may be due to poor contact of the wires at the terminals of the electronic board. The unit has a ground-color cable (green/yellow) that serves as a common signal for thermostats, probes and pressure switches. If the dough is not good, it may give a bad contact error. Always check the terminals of the electronic Board, as well as quick connectors and connectors of the safety elements and probes to avoid faults due to bad contact.

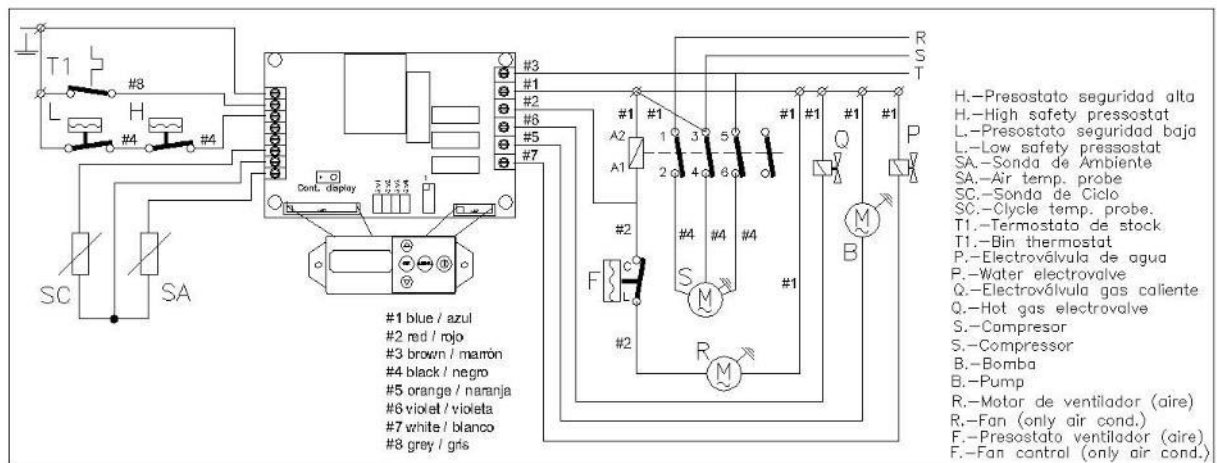

ALARMS

FULL BIN OF ICE

- Indicates that the ice storage bin is full, by contacting the ice with the storage probe, the unit will stop at the end of harvest. When removing the ice from the bin and lowering its level, the unit automatically rearming.
- If there is no bin (freefall) or no ice on the storage probe (located at the bottom left of the evaporator access door of the unit, inside the metal tube), check that the probe is working properly.



- The probe may have a wire cut or disconnected (check that the cable is properly connected to the terminal of the electronic board). Check mass/Common (the Unit chassis ground is used as common for plate input signals).
- The probe has a wheel to change the opening temperature of the internal thermostat (from + 3°C to + 5 °C approx.), regulate with the wheel if necessary.
- In the case of not using a storage probe (free fall to conveyor belt or similar), cancel the stock thermostat by short circuit it.
- If even with the bridged thermostat the unit continues to stop the alarm, change the electronic board.

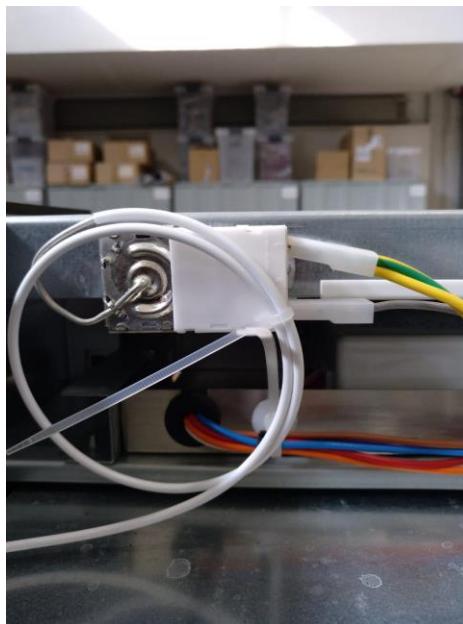

Stock thermostat

CYCLE PROBE

- The temperature of the cycle probe is displayed. If defective, the machine will stop and indicate "cycle probe alarm". Stops the unit.
- Check that the probe is properly connected to the electronic board and that the cable is not cut.
- If you need to change the cycle probe, you can take advantage of the ambient probe, and use it to change it to cycle. Remember to connect correctly to the electronic board.
- The cycle probe is placed in the suction outlet of the evaporator, after the evaporator

curve (old units are caught in the evaporator with flanges). Place the new probe just like the previous one, holding it correctly so that it makes a good contact

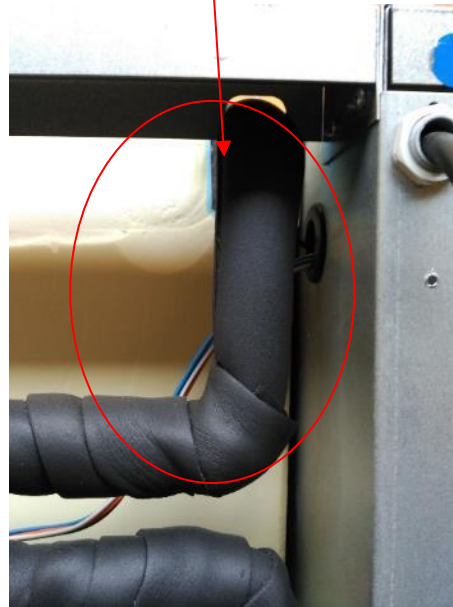
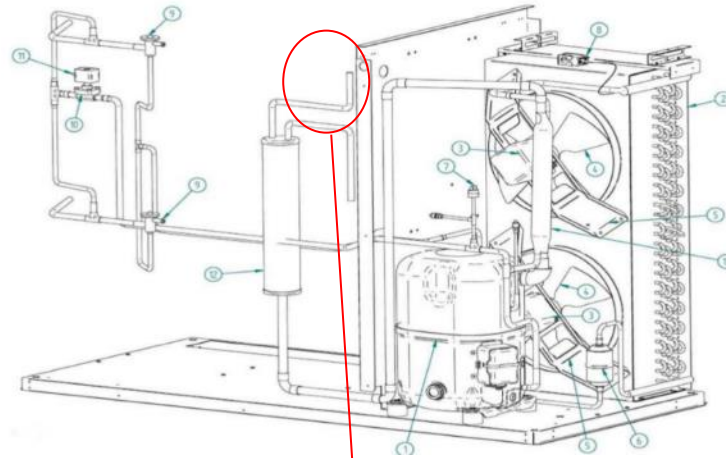

AMBIENT PROBE

- If by any reason the probe is defective, instead of indicating the temperature, it will indicate "_____". This alarm will not affect the operation of the machine as it is only an informative function.
- It is not necessary to install the ambient probe for the unit to function properly.

PRESSURE ALARM

- The unit has a low-and high-pressure switch connected together. The alarm indicates both low pressure and high pressure failure. The unit would stop with the pressure alarm immediately.
- The alarm is manual reset, turning the unit off and on, provided that dip-switch 2 is off (factory default). For manual reset, set dip-switch 2 to ON. The display will then indicate

instead of alarm pressure the word "timing".

- After 60 minutes it will restart automatically (in automatic mode).
- In the event of a pressure shutdown, the first thing with the unit stopped is to check that the quick connectors connecting the pressure switches with the electronic board are connected, and that they are not loose. Also check that the cables are not cut, and that they are correctly connected to the terminals of the electronic board.
- If any cables are grounded or broken, replace or improve the connection and restart the unit.
- If you have the wiring for the pressure switches correctly attached, check the pressure switches. To do this, place manometers in high and low, and check continuity in the pressure switches.
- Keep in mind that the safety switch rearms at 22 bars (if above 22 bars will not give continuity, wait for the pressure to decrease with the unit stopped). The low pressure switch is open over 0.8 bar, check that we have low pressures above 1 bar.
- If any of the pressure switches is still open with the low above 1 bar and the high one below 22 bars, proceed to replace the defective pressure switch.
- The low pressure switch can be bypassed while it is being replaced. The high one should never be bypassed to ensure no breakage of the compressor and piping.
- If the pressure switches are working properly, proceed to turn the unit on with the manometers in high and low and check working pressures. Below are detailed high and low pressure failures:
 - If the low pressure comes down below 0.8 bar, the low switch will open, giving alarm pressure. If it happens, check that we do not have refrigerant leakage (stop the unit, with R404A must have over 8 bars of pressure). If there is a leak, find it and repair it.
 - Or if we have a remote unit, it may occur that the liquid solenoid coil does not work, not opening when the unit is turned on and lowering the low pressure to zero. Replace the coil.
 - Or with remote unit, if the outside temperature is low (below -3°C or -4°C), the liquid can be in the condenser, and will not return to the compressor, which will stop by low pressure (remote condenser is designed to work from 0°C to + 43°C).
 - Or if the high pressure exceeds 30 bar, the unit will give pressure alarm. Check that the condenser is working properly:

Air Compact Unit: Check that the condenser fans operate and work properly, if it does not work, check that the condensate pressure switch sends the voltage to the fans. Replace the switch if need it or the fan.

Check that the air entering the condenser does not have a very high temperature, that the air outlet does not return to the condenser inlet, and that the unit is not in a closed room without ventilation.

Air Remote Unit: Check that the condenser fans operate and work properly, if it does not work, check that the condensate pressure switch sends the voltage to the fans. Replace the switch if need it or the fan.

Check that the air entering the condenser does not have a very high temperature, that the air outlet does not return to the condenser inlet, and that the unit is not in a closed room without ventilation. It is advisable that the sun does not directly hits the remote condenser. If possible place the condenser under a roof.

LONG PREHEATING

- If the harvest time is longer than the set time, the alarm "long time-out alarm" appears on the display.
- Check that the parameters of the electronic board are correct (harvest temperature at -8°C or 0°C in units with probe cycle on evaporator). The maximum harvest time, it must be 5 minutes.
- Check that no ice cake has been built in the evaporator area, if so, look at the manufacturing time, if it is too long it will not be able to harvest. Rectify parameter.
- To avoid ice cakes by low temperatures in the area of the units, there is a parameter time maximum machine, which allows to activate the entry of the water pumps without anything else, causing a defrost, selectable for hours, and in parallel with the time pump defrost, indicating time defrost duration (default 30 minutes).
- Check that the cycle probe reads correctly, if not replace.
- Check that the hot gas solenoid valve opens during harvest, if not check coil, replace if defective. If the valve is blocked, replace it.
- Check that water enters with harvest to the evaporator. If not, check solenoid valve, if defective replace it. If it works correctly replace the electronic board.
- Check that the water pump acts during the start of the harvest to help, time initial harvest pump, always above 30 seconds.

LONG PRE COOLING

- In the event that the manufacturing time is longer than the set time, the machine would stop displaying the alarm "long fab time alarm" on the display.
- The alarm may be due to several faults. First check the electronic board, that the cycle probe is correctly installed, and that the manufacturing temperature parameter is correct (-8°C , 10°C in units with cycle probe installed in the evaporator).
- Check the parameter maximum manufacturing time, it must be 60 minutes.
- Cycle probe failure, does not read correctly, replace.
- Refrigerator problem. Check that the compressor is working properly and that the evaporator is frosted.
- Check that the water inlet valve is not continuously open, if so replace it.
- Check that we do not have the hot gas solenoid valve open (the outlet hot gas valve pipe is hot). Possible opening and not closing due to mechanical failure, dirt in the valve seat (recover coolant, open and check seat for replacement), or stiff spring problem (test with a coil magnet to actuate the solenoid valve several times).
- Check that the expansion valves modulate correctly, and check that the bulb is properly installed, without moving, making good contact with the suction pipe. If it is a failure of the expansion valve, replace, or properly hold the bulb.
- Check working pressures, to see possible refrigerant leak or condenser malfunction.
- In remote units, check that the liquid solenoid valve is fully open.

SHORT PRE COOLING

- If the manufacturing time is shorter than the minimum variable manufacturing time, the machine will start a harvest. If the error continues, the "short T. Fabric Alarm" display will appear.
- The alarm may be due to several faults. First check the electronic board, that the cycle probe is correctly installed, and that the manufacturing temperature parameter is

- correct (-8°C, 0°C in units with cycle probe installed in the evaporator).
- Check the parameter minimum manufacturing time, it must be 2 minutes.
 - Cycle probe failure, does not read correctly, replace.
 - Check the hydraulic part of the unit, if water does not reach the unit, it cools down much faster, giving the alarm. Check that the water solenoid valve opens during the harvest of the ice cubes, and that we have enough water pressure in the mains.
 - Check the pumps, which are properly watered, that the arms rotate and are not loose. Also check the suction filter of the water pump.
 - Check that there is no ice cake in the evaporator, if it has been produced, it will read the temperature below the assigned value and the alarm shall be tripped. If there is an ice cake, on the evaporator or under it, check that the harvest is done correctly (alarm long Preheat).